



## Performance analysis of a solar-powered maize sheller: production capacity and shelling efficiency

Hendradinata, Firdaus, Toni Okviyanto\*, Tri Satya  
Ramadhoni, Muhammad Rizky Tolusha Putra, Muhammad  
Hafidzni Muttaqin, Taufikurrahman

Department of Mechanical Engineering, Sriwijaya State  
Polytechnic, Palembang 30139, Indonesia

\*Corresponding author: [toni.okviyanto@polsri.ac.id](mailto:toni.okviyanto@polsri.ac.id)

### Abstract

Post-harvest mechanization is essential for improving productivity and reducing labor intensity in smallholder agriculture. This study aims to design and test the performance of a portable solar-powered maize sheller prototype developed as an environmentally friendly and cost-effective alternative for rural farmers. The research employed an engineering design approach consisting of mechanical and electrical system design, prototype fabrication, and performance testing by comparing solar-powered and grid-powered machines. The key parameters analyzed included shelling capacity, shelling efficiency, energy efficiency, grain damage rate, battery charging time, and operating cost. The results showed that the prototype achieved a shelling capacity of 65 kg/h with a shelling efficiency of 90% and a grain damage rate of 5%, comparable to grid-powered machines (91.4%) and higher than fossil fuel-based machines (85%). The prototype's energy efficiency was recorded at 62.5%, lower than a grid-powered-based machine (80%) due to conversion losses in the panel, battery, and inverter, but still superior to fuel-based machines (35%). Economic analysis indicated that the solar-powered machine had the lowest operating cost, only IDR 5.3/kg, compared to grid electricity at IDR 7.3/kg and fuel-based machines at IDR 115/kg. Equipped with a 12 V–20 Ah battery and a 200 Wp solar panel, the machine can operate independently with a charging time of about six hours under optimal solar radiation. This research demonstrates the feasibility of solar energy utilization in maize shelling as an efficient, economical, and environmentally friendly solution.

### Keywords:

Energy efficiency, maize sheller, solar energy, solar panel.

### 1 Introduction

The utilization of solar energy in the agricultural sector is increasing globally as part of the transition toward clean energy, reduced carbon emissions, and enhanced food production efficiency [1], [2]. Renewable energy-based technologies have become key solutions for agricultural mechanization, particularly in developing countries that still face various limitations in energy infrastructure [3]. Numerous studies have shown that integrating solar panels into agricultural tools and machinery can reduce dependence on fossil fuels, lower operational costs, and improve access to mechanization in remote areas. This global trend is highly relevant to Indonesia, an agrarian country with abundant solar radiation throughout the year and persistent challenges related to uneven electricity access in many rural regions [4], [5], [6].

Maize is one of the most strategic food commodities, playing a major role in supporting food security and the Indonesian economy [7]. As the second most important staple crop after rice, maize

serves not only as a vital source of carbohydrates for the population but also as a primary raw material for the animal feed industry and modern food processing [8]. National demand for maize continues to increase significantly, driven primarily by the growing need for poultry feed in line with the expansion of the livestock industry. On the other hand, domestic maize production is still dominated by smallholder farmers with limited land and simple technology [9], [10]. This condition results in suboptimal productivity and relatively low post-harvest efficiency. One of the most critical post-harvest stages determining the quality of the yield is shelling, namely the process of separating maize kernels from the cob [11], [12].

Maize shelling is still largely carried out manually or with simple tools such as wooden beaters. This method is highly inefficient as it requires a long processing time, demands significant physical effort, and often results in fatigue or even injuries for farmers. Moreover, manual shelling frequently produces non-uniform results and a relatively high level of grain damage. In large-scale production, such manual methods are clearly incapable of meeting demand. Therefore, mechanization through the use of maize shelling machines has become essential to improve efficiency, accelerate the process, and reduce labor costs [13], [14], [15], [16], [17].

The use of fossil-fuel-powered maize shelling machines can significantly increase work capacity compared to manual methods; however, they present notable drawbacks. High operational costs arise from substantial fuel consumption and fluctuating fuel prices, while exhaust gas emissions contribute to air pollution and elevated CO<sub>2</sub> levels, and noise from the engines reduces workplace comfort [18], [19], [20], [21], [22]. Grid-based electric machines (PLN) are relatively more environmentally friendly and stable, yet their adoption in many rural areas remains limited due to inadequate electricity infrastructure and the rising cost of electricity [18], [23]. These conditions underscore the importance of developing agricultural technologies based on alternative energy sources that are more autonomous, efficient, and sustainable [21], [22], [23], [24], [25], [26].

Solar energy represents one of the most promising renewable energy sources. As a tropical country with an average daily solar radiation intensity of 4.8–5.1 kWh/m<sup>2</sup>, Indonesia has a comparative advantage in utilizing solar energy for agricultural applications [27], [28]. Solar energy is clean, renewable, and available throughout the year, and it has been widely applied to water pumps, crop dryers, and egg incubators. However, its application in maize shelling machines remains relatively limited, despite substantial evidence from various studies highlighting its potential [21], [29], [30], [31], [32]. Ghritalahre et al. developed a maize sheller with a capacity of 174.33 kg/h powered by a 250 W Direct Current (DC) motor, achieving a shelling cost of only 0.266 Rs/kg, thereby demonstrating superior energy efficiency and cost-effectiveness [33]. Ezurike et al. designed a maize shelling machine driven by an electric motor with a shelling efficiency of 91.4%, but its reliance on the national electricity grid (PLN) poses challenges for farmers in areas with limited access to electricity [34]. Meanwhile, Ravindran et al. developed a mini corn shelling machine with a power rating of 399.2 W, achieving an efficiency of over 90% and featuring a portable, low-cost design, which makes it particularly suitable for smallholder farmers [35].

Recent studies have demonstrated that solar energy holds significant potential as a reliable alternative resource for both industrial and agricultural sectors. A 10 kWp on-grid PV system installed at Tonasa V Factory recorded a Performance Ratio (PR) of 83% with an average efficiency of 15.3%, confirming the reliability of solar energy for large-scale applications as well as agricultural machinery [36]. Exergy analysis of a solar–biomass hybrid system reported an exergetic efficiency of 21.28% with an energy payback period of only 1.02 years [37], while simultaneously achieving a substantial reduction in carbon emissions. Other innovations, such

as the use of crab shell as a natural energy storage material in solar stills, successfully increased efficiency from 17% to 30.74% [38]. Furthermore, research on small-scale heliostat field layouts emphasized that optical design optimization plays a critical role in enhancing solar energy capture [39].

Fossil-fuel-powered maize shellers offer advantages in terms of energy availability compared to conventional sources, but they are burdened with high operational costs and significant environmental impacts. Grid-powered machines are relatively cleaner and provide stable performance; however, their accessibility in rural areas is still limited, and electricity prices continue to rise. In contrast, solar-powered shellers require a relatively high initial investment but provide nearly zero operational costs, energy independence, and long-term sustainability [40]. A study by Silaban and Sitompula reported that a 450 Wp solar photovoltaic system achieved an efficiency of 14.4–15.3% with a battery charging time of approximately 8 hours [41]. Although this efficiency is lower than the average transmission efficiency of grid electricity, which ranges from 30–35%, its economic advantage is substantially greater. Over a 10-year period, the operational costs of solar PV systems are estimated to be up to 80% lower than those of grid electricity or diesel generators [36]. These findings highlight that despite the relatively lower energy conversion efficiency, solar power remains more advantageous in the long term, particularly for smallholder farmers in rural areas who face limited access to electricity and rising fossil fuel prices. Although solar energy technologies have been widely applied in irrigation systems, drying units, and water pumps, research on solar-powered maize shelling machines remains scarce. Most existing studies focus either on mechanical design or on the integration of solar panels, without providing a comprehensive assessment that includes machine performance, energy efficiency, grain quality, and economic feasibility. This highlights a critical research gap: it is still uncertain whether solar-powered maize shellers can match or surpass grid-powered and fossil fuel-based alternatives across these key dimensions.

This research aims to develop a prototype of a portable maize sheller that is efficient, environmentally friendly, and economically viable. The prototype will be evaluated based on key performance parameters, including shelling capacity per hour, energy efficiency, battery charging time, and grain damage rate. In addition to performance testing, this study explicitly conducts a comparative analysis by evaluating the prototype against grid-powered maize shellers and fossil-fuel-powered machines to determine its relative efficiency, operational feasibility, and potential advantages. Beyond the technical innovation, this study contributes to the national renewable energy transition agenda, carbon emission reduction, and the strengthening of food security at the smallholder farmer level. The technology is expected to provide a practical solution for farmers in remote areas by improving work efficiency, reducing operational costs, and supporting sustainable agricultural development. Ultimately, this research is anticipated to serve as a model for the application of green technology in agriculture by integrating technical, economic, and environmental aspects.

## 2 Research methodology

The research methodology was designed using an engineering design approach combined with experimental testing, with the aim of developing a portable solar-powered maize sheller prototype that is efficient, environmentally friendly, and tailored to the needs of smallholder farmers. The study was structured into four main stages: initial data collection, system design, prototype fabrication, and performance testing and analysis. Each stage was systematically arranged to ensure that the resulting prototype is not only technically feasible but also practically applicable in the field [42].

### 2.1 Data collection

The initial stage of the research was carried out through direct field observations and interviews with farmers and farmer groups

as potential end-users. The primary objective of this activity was to identify the actual needs of users, understand the challenges encountered in maize shelling when performed manually or with conventional machines, and explore farmers' preferences regarding machine size, production capacity, energy source, and ease of operation. The outcomes of this stage served as the foundation for developing the User Requirement Specification (URS), which guided the subsequent design process.

### 2.2 System design and development

The solar maize sheller consists of two frames, namely the main frame and the middle frame. The main frame functions to support all components used, while the middle frame functions to hold the main components, namely the 250 W AC motor, pulley, and corn sheller set. The dimensions of the main frame used to support all components are 600×500×1800 mm, and the middle frame is 430×160×12 mm. Both frames use L-shaped bars with dimensions of 40×40×3 mm. ST 37 material is used for these profile bars with material properties of elastic modulus, tensile strength, Poisson's ratio and material density of 210 GPa, 370–400 MPa, 0.3 and 7850 kg/m<sup>3</sup>, respectively. All support bars connected to the main frame are welded to withstand axial forces, normal forces, and moments. Three support bars that hold several components on the main frame. The first support bar, located at the top, will hold the load from a 200-WP solar panel weighing 3.5 kg. The second support bar, located below it, functions to hold the SCC, inverter, cables, small accessories weighing 1.0 kg, and a 12 V 40 Ah SLA battery weighing 12.0 kg. The third support beam functions to hold the main component with a total weight of 5.5 kg. The design was created using SolidWorks software. L-profile beams were used because, in addition to being strong enough to support the components, they are also more economical than other profiles. The material strength calculation for the beams was performed by determining the free-body diagram on the support beams. The analysis was then continued using the Eq. (1) [43].

$$\sigma_{maks} = -\frac{M \cdot c}{I} \quad (1)$$

The design stage encompassed both mechanical and electrical aspects. On the mechanical side, the design included the shelling drum, maize feeding unit, supporting frame, and power transmission system [1], [44]. On the electrical side, the system design involved selecting a solar panel with sufficient capacity to meet the power requirements of the prototype, calculating the appropriate battery capacity, and determining the suitable solar charge controller and inverter. The overall design was developed using SolidWorks CAD software to produce accurate 3D models and technical details. The key parameters considered included motor power demand, battery capacity, solar panel area, and the efficiency of the photovoltaic system. In this prototype, an Alternating Current (AC) motor is used; requiring an inverter to convert the DC generated by the solar panel and battery into AC compatible with the motor. The AC motor was selected due to its advantages in delivering stable output power, high durability, and reliable performance under varying shelling loads. The complete configuration of the maize sheller prototype developed in this study is illustrated in Fig. 1, which highlights the structural framework, mechanical components, and overall system integration. The key components and their corresponding technical specifications used throughout the design and assembly process are detailed in Table 1, providing a comprehensive overview of the elements that support the machine. Furthermore, the 3D design model of the solar-powered maize sheller is presented in Fig. 2, offering a clearer visualization of the system layout, including the placement of the solar panel, motor unit, and supporting frame.

The determination of the technical specifications was based on an analysis of the functional requirements of a portable maize shelling machine intended for small-scale farmers, namely that the

machine must be energy-efficient, easy to operate, resistant to field conditions, and capable of operating independently without reliance on grid electricity [45]. Based on these general requirements, mechanical workload calculations were carried out using the target machine capacity (kg/h) and the characteristics of dried maize with standard moisture content, thereby obtaining the required shaft rotational power and torque that must be provided by the drive system.

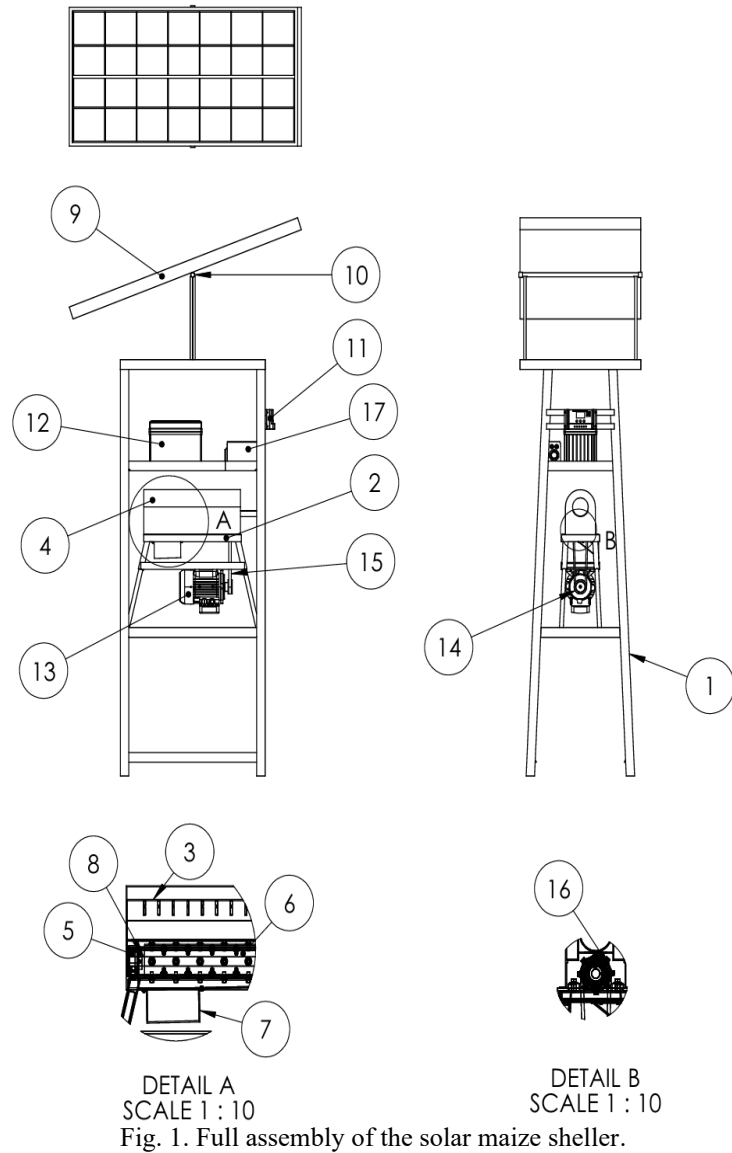

Fig. 2. Design of the solar maize sheller.

Based on the calculated power requirements, a 12 V AC electric motor with a rated power of 200 W was selected because of its ability to deliver stable output power, high durability, and reliable performance under varying load conditions, which made it suitable for solar-based operation. Furthermore, the capacity of the 200 Wp solar panel and the 12 V–20 Ah battery was determined through calculations of total energy demand during operating cycles, effective working time, and estimated recharge time using solar irradiance data from the test location. The selection of structural components, such as angle steel frames (steel L 40×40 mm), carbon steel shafts, protective plates, pillow block bearings, and the pulley–V belt transmission system, was based on material strength analysis, safety factors, local material availability, and ease of manufacturing. All technical specification decisions were not only based on theoretical considerations, but were also validated through literature studies, machine design standards, and empirical experience from similar machines, so that Table 1 represents the final outcome of a rational, measurable, and application-oriented specification selection process for a solar-powered maize shelling machine that is efficient, economical, and suitable for rural environments.

### 2.3 Prototype fabrication

The prototype was fabricated at the Production Workshop of the Mechanical Engineering Department, Politeknik Negeri Sriwijaya, using locally available materials to reduce production costs. The fabrication process was carried out in several sequential stages. First, the frame was constructed from steel L (40×40 mm) through cutting, welding, and surface finishing to ensure rigidity and

Table 1. Components of the maize sheller

Component	Specification
Frame	Steel L profile, 600×500×1800 mm
Central frame	Steel L profile, 430×160×125 mm
Inner cover	Protective casing for internal mechanisms
Outer cover	Protective casing for the entire machine
Pillow block	2 units, inner diameter 16–17 mm
Discharge channel	Inclined aluminum plate
Shelling cylinder (teeth)	Circularly embedded steel teeth
Shaft (17 mm)	Carbon steel, length ±300 mm
Solar panel	200 Wp, monocrystalline
Shaft (16 mm)	Carbon steel
Solar charge controller	10 A, 12/24 V automatic
Battery	12 V, 20 Ah sealed lead-acid
AC motor	12 V, 200 W, high torque
Pulley (2 inch)	Steel, diameter 50.8 mm
V-belt	Standard size 1-1
Pulley (2.5 inch)	Steel, diameter 63.5 mm
DC to AC inverter	300 W output

durability. Second, the shelling drum, equipped with circularly arranged steel teeth, was installed on a carbon steel shaft supported by pillow block bearings, providing stability and smooth rotation. The transmission system, consisting of pulleys and a V-belt, was then mounted to transfer torque efficiently from the AC motor to the shelling drum (Fig. 3).

The electrical side, a 200 Wp mono-crystalline solar panel was connected to a 10A solar charge controller, which regulates the charging of a 12 V–20 Ah sealed lead-acid battery. High-torque AC motor 200 W was integrated as the main driving unit, supported by an inverter 300 W output for DC–AC conversion when required. After all mechanical and electrical subsystems were installed; an initial functional test was conducted to check alignment, power transmission, and electrical connectivity. Any technical issues identified during this stage were resolved through troubleshooting and fine-tuning adjustments. Only after ensuring proper integration of all components did the prototype proceed to the full-scale performance testing phase.



Fig. 3. Prototype of the solar-powered maize sheller.

## 2.4 Performance testing

The performance testing was conducted under two different scenarios, namely utilizing energy supplied by the solar panel system and using electricity from the national grid (PLN) as a comparison. The primary parameters measured included: (1) shelling capacity; (2) shelling efficiency; (3) energy efficiency; (4) Kernel damage rate; (5) battery charging time.

Shelling capacity is the amount of maize kernels successfully shelled within a given unit of time [46], [47], [48]. Eq. (2) defines the shelling capacity,  $Q$  (kg/h), as the rate of maize shelling, calculated as the ratio between the mass of successfully shelled kernels  $m_{shelled}$  (kg) and the machine operating time  $t_{operation}$  (h).

$$Q = \frac{m_{shelled}}{t_{operation}} \quad (2)$$

Shelling efficiency was defined as the percentage of maize kernels that were successfully separated cleanly from the cob [4], [46], [48]. Eq. (3) defines the shelling efficiency,  $\eta$  (%), which is defined as the ratio of the mass of successfully shelled kernels  $m_{shelled}$  (kg) to the total mass of maize before shelling  $m_{maize}$  (kg), expressed as a percentage.

$$\eta = \frac{m_{shelled}}{m_{maize}} \times 100\% \quad (3)$$

Energy efficiency was determined as the ratio between the motor's consumed energy and the total available energy supplied by the solar panel or battery, expressed as [46], [49]. Eq. (4) represents the energy efficiency,  $\eta_{energy}$  (%), defined as the ratio of the electrical energy consumed by the motor  $E_{motor}$  (Wh) to the total electrical energy supplied by the solar panel or battery  $E_{input}$  (Wh).

$$\eta_{energy} = \frac{E_{input}}{E_{motor}} \times 100\% \quad (4)$$

The calculation of the total energy supplied by the solar panel or the battery during the operation of the maize sheller is given by [46], [49]. Eq. (5) describes the total input energy  $E_{input}$  (Wh) as the product of the electrical power supplied by the solar panel or battery  $P_{input}$  (W) and the machine operating time  $t_{operation}$  (h).

$$E_{input} = P_{input} \times t_{operation} \quad (5)$$

The electrical energy consumed by the motor is calculated as [46], [49]. Eq. (6) defines the electrical energy consumed by the motor  $E_{motor}$  (Wh) as the product of the motor power  $P_{motor}$  (W) and the operating time  $t_{operation}$  (h).

$$E_{motor} = P_{motor} \times t_{operation} \quad (6)$$

Kernel damage rate is the proportion of broken or damaged kernels during shelling, expressed as [4], [48], [50]. Eq. (7) defines the kernel damage rate DR (%) as the ratio of the mass of broken or damaged kernels,  $m_{damaged}$  (kg) to the total mass of shelled kernels  $m_{total}$  (kg), expressed as a percentage.

$$DR = \frac{m_{damaged}}{m_{shelled}} \times 100\% \quad (7)$$

The measurement of grain damage was carried out through a manual separation procedure after the shelling process was completed. The kernels discharged from the machine were collected and then visually sorted into two categories: intact kernels and broken kernels. The separation was performed by spreading the shelled output onto a flat tray and manually removing the broken kernels, leaving only fragments and visibly damaged kernels. Both groups (intact and broken kernels) were subsequently weighed using a digital scale. The damage percentage was calculated as the ratio of the mass of broken kernels to the total mass of kernels produced in each trial. This procedure was consistently applied across all test replications [47].

Battery charging time is the duration required to fully charge the battery under clear-sky and cloudy conditions. The performance evaluation began with measuring solar radiation intensity as the basis for designing the solar power system used in the maize sheller prototype. Measurements were carried out throughout the day under three weather conditions: clear, cloudy, and overcast to obtain radiation profiles that accurately represent field variability.

These intensity data were then utilized to calculate the required power, determine the appropriate sizing of the 200 Wp solar panel, and select the 12 V–20 Ah battery as the primary energy storage unit. Afterward, the system was assembled using a solar charge controller to regulate the charging process and prevent overcharging. The performance tests were conducted repeatedly to ensure consistency and reliability of the data, and the resulting measurements were compared with findings from previous studies to identify performance differences and highlight the advantages offered by the developed prototype [51], [52].

## 2.5 Data analysis

The experimental data were analyzed using a descriptive-comparative approach, in which the performance of the solar-powered maize sheller was evaluated against that of the national electricity grid (PLN) and fossil fuels. Each performance test was

conducted three times ( $n = 3$ ) to ensure data consistency and scientific reproducibility. The values reported in the results represent the average of these three replicates. Each experiment utilized 100 kg of maize, although performance analysis was conducted based on the shelling output per hour using a stopwatch and digital scales. The initial moisture content of the kernels was measured using a digital grain moisture meter and conditioned to 12-14% (wet basis), in accordance with the Indonesian standard SNI 01-3920-2006 for dried shelled maize, to prevent kernel damage resulting from excessively high or excessively low moisture levels [50]. The analysis covered three major dimensions: (1) technical aspects, including shelling capacity, energy efficiency, and grain quality; (2) economic aspects, particularly operating costs per kilogram of shelled maize; and (3) environmental aspects, focusing on the potential reduction of CO<sub>2</sub> emissions compared to fossil-fuel-based machines. The outcomes of this analysis provide a comprehensive assessment of the technical feasibility, economic viability, and sustainability of adopting solar-powered maize shellers for smallholder farmers in rural areas.

### 3 Results and discussion

This study aims to evaluate the technical, economic, and environmental feasibility of a portable solar-powered corn sheller prototype. The analysis was conducted by comparing two energy sources, namely photovoltaic solar panels and grid electricity (PLN), while conventional fossil fuel-powered machines were used as an external benchmark. The discussion focuses on key performance indicators, including shelling capacity, energy efficiency, kernel damage rate, as well as the economic implications and environmental sustainability associated with the adoption of this technology.

#### 3.1 Shelling capacity

Shelling capacity represents one of the key parameters in evaluating the performance of a corn shelling machine, as it directly reflects the productivity level of the equipment in processing harvested crops. A higher shelling capacity indicates that a larger quantity of corn can be processed within a given period, thereby improving labor efficiency for both individual farmers and farmer groups. Consequently, this parameter is essential in determining not only the operational effectiveness of the prototype but also its potential contribution to enhancing post-harvest handling and overall agricultural productivity.

Table 2 illustrates the comparative shelling capacities of different corn shelling methods. Manual operation produces only about 15 kg/h, which is highly inefficient for larger-scale applications. Fossil-fuel-powered machines achieve the highest capacity, ranging from 150 to 180 kg/h [33], [53], [54], but this comes at the expense of high operating costs and significant environmental impacts. Grid-powered maize shelling machine (PLN) offers a capacity of 90–110 kg/h [34], [54], [55], with the advantage of stable operation, though their use remains limited in rural areas due to restricted grid access. Meanwhile, the solar-powered prototype achieves a shelling capacity of 65 kg/h, which is lower than both PLN and fossil-fuel machines but represents a considerable improvement over manual methods, while offering the added benefits of energy independence and sustainability.

Table 2. Comparison of corn shelling capacity

Type of machine	Capacity (kg/h)	Reference
Manual (human-powered)	15	Manual testing results
Solar machine (prototype)	65	Prototype testing results
Fossil-fuel engine (gasoline/diesel)	150–180	[33], [53], [54]
Grid-powered machine (PLN)	90–110	[34], [54], [55]

#### 3.2 Shelling efficiency

Shelling efficiency reflects the quality of machine performance, as it indicates the proportion of corn kernels that can be cleanly

separated from the cob relative to the total mass of corn processed. A higher efficiency value demonstrates superior machine performance in terms of minimizing kernel loss [35], [56], [57], [58]. Efficiency is typically calculated by comparing the mass of successfully shelled kernels to the initial mass of corn, thereby providing a direct measure of the machine's effectiveness. High efficiency values not only signify optimal operational capacity but are also closely associated with harvest quality, as kernel damage and unshelled residues are minimized [59]. Thus, shelling efficiency serves as a critical indicator in evaluating the technical feasibility of a corn shelling machine.

Table 3 shows that the manual method has the lowest efficiency (70%). The gasoline engine improves efficiency to 85% [33], [53], [54], but it comes with high operational costs and causes pollution. The PLN-based machine achieves the highest efficiency at 91.4% [34], [38], [55], [59], [60] because of a stable energy supply, though it is limited to areas with electricity access. The portable mini machine records similar efficiency, between 90% and 92% [35], but with a smaller production capacity. The solar-powered prototype in this study demonstrates an efficiency of 90%, almost on par with the PLN machine.

Table 3. Shelling efficiency

Type of machine	Efficiency (%)	Reference
Manual (human-powered)	70	Manual testing results
Solar machine (prototype)	90	Prototype testing results
Fossil-fuel engine (gasoline/diesel)	85	[33], [53], [54]
Grid-powered machine (PLN)	91.4	[34], [38], [55], [59], [60]
Portable mini machine	90	[35]

#### 3.3 Energy efficiency

Shelling efficiency is an important parameter that can be used as a basis for comparing different types of machines to assess the performance of maize shellers. Each drive system, whether manual, fossil fuel-powered, PLN electricity-based, or solar-powered, has distinct characteristics that affect the quality of the results.

Table 4 shows the energy efficiency, which is one of the important parameters for evaluating the performance of maize shelling machines based on the energy source used. Fossil fuel-powered machines, such as gasoline or diesel engines, have low efficiency, around 35% [33], [61], due to significant heat losses during the conversion of chemical energy to mechanical energy. This makes fuel-powered machines energy-inefficient and less environmentally friendly, despite their high shelling capacity. PLN-based electric machines show much higher efficiency, around 80% [34], [35], [62], [63], [64], with a stable energy supply, enabling consistent performance. Solar-powered machines, while having lower efficiency at 62.5%, experience losses in the panel, Solar Charge Controller (SCC), battery, and inverter.

Table 4. Comparison of energy efficiency in maize shelling machines

Type of machine	Energy efficiency (%)	Reference
Solar machine (prototype)	62.5	Prototype testing results
Fossil-fuel engine (gasoline/diesel)	35	[33], [61]
Grid-powered machine (PLN)	80	[34], [35], [62], [63], [64]

The system energy efficiency of 62.5% indicates that a portion of the available energy is not fully utilized by the drive motor due to energy losses occurring in each system component. Energy losses in the solar panel are mainly attributed to the limited conversion of solar radiation into electrical energy and the effect of elevated surface temperatures, which increase internal resistance. In the battery, energy losses occur during the charging and discharging processes, causing part of the energy to be dissipated as heat. The inverter introduces conversion losses due to the

transformation of DC into AC, which is inherently imperfect. Meanwhile, in the electric motor, energy losses arise from mechanical losses (bearing and transmission friction) as well as thermal losses in the windings. The cumulative effect of these losses across all components results in only about 62.5% of the input energy being effectively utilized for the shelling process.

### 3.4 Kernel damage rate

Kernel damage is an important indicator for evaluating the quality of shelling performance, as it represents the percentage of kernels that become broken or damaged during the process. The level of kernel damage strongly determines the final quality of shelled maize, since broken kernels can reduce market value, increase the risk of contamination, and decrease the efficiency of subsequent post-harvest processes. To ensure an accurate evaluation of kernel damage, the assessment was preceded by measuring the moisture content of the maize, which was maintained at 14%, in accordance with the quality standards for dried shelled maize. Moisture content was measured using a digital grain moisture meter through random sampling of the tip and base sections of six maize cobs. This approach ensured that the measured moisture values accurately represented the overall condition of the material and were not affected by moisture variation within a single cob. Maintaining consistent moisture content is crucial because it directly influences shelling quality and the resulting level of kernel damage. The measured results are summarized in Table 5 to illustrate the differences in kernel damage levels across various types of maize shelling machines.

Table 5. Kernel damage rate in maize shelling machines

Type of machine	Kernel damage rate (%)	Reference
Manual (human-powered)	3	Manual testing results
Solar machine (prototype)	5	Prototype testing results
Grid-powered machine (PLN)	6	[34], [65], [66]
Fossil-fuel engine (gasoline/diesel)	12	[27], [37], [38], [39]

Table 5 shows the percentage of kernel damage in maize shelling. The test results for the solar-powered maize sheller prototype indicate a kernel damage rate of around 5%, which is still acceptable within post-harvest quality standards. This value is relatively low compared to fossil-fuel machines, which have a damage rate of 12% [27], [37], [38], [39] due to the instability of their rotational speed, and is similar to the performance of the PLN-based machine with an average damage rate of 6% [34], [65], [66].

The main factors affecting kernel damage are cylinder speed, cylinder design, and corn moisture content. Excessively high speeds increase capacity but risk higher kernel breakage, while low speeds reduce capacity but maintain better kernel quality. Moreover, moisture content has a significant impact. Corn with excessively high moisture content is difficult to separate, reducing efficiency, while corn with very low moisture content becomes fragile and easily breaks. Therefore, motor speed control and the selection of optimal harvest timing with appropriate moisture content are key factors in minimizing kernel damage to maintain acceptable quality.

Manual shelling has low efficiency due to heavy reliance on human power, while fossil-fuel machines excel in capacity but often result in higher kernel damage. PLN-based machines achieve high efficiency with clean results, while the solar-powered prototype offers efficiency close to that of the PLN machine.

### 3.5 Battery charging time and solar radiation intensity

Fig. 4 illustrates the variation in solar radiation intensity throughout the day under three different weather conditions: clear sky, cloudy, and overcast. In general, the radiation intensity increases from morning, reaches its peak around 12:00–13:00, and

then gradually decreases toward the late afternoon. Under clear-sky conditions, the radiation intensity is the highest, starting at 150 W/m<sup>2</sup> at 07:00 and reaching a maximum of 850 W/m<sup>2</sup> at 12:00 before declining to 0 W/m<sup>2</sup> at 17:00. Cloudy conditions exhibit a similar pattern but with lower values, rising from 80 W/m<sup>2</sup> to a peak of 450 W/m<sup>2</sup> between 11:00 and 12:00, while overcast conditions produce the lowest radiation levels, ranging only between 40 and 200 W/m<sup>2</sup> throughout the observation period. These variations in solar irradiance are directly related to the performance of the photovoltaic charging system used in the maize sheller prototype. The prototype employs a 12 V–20 Ah battery with an energy capacity of approximately 240 Wh, selected to meet the sheller motor's power requirement of 125 W for about two hours of operation. A 200 Wp solar panel serves as the primary energy source, supplying power through a solar charge controller. Under optimal radiation conditions, such as those represented by the clear-sky curve, the solar panel can operate near its nominal capacity, enabling a full battery recharge in approximately six hours. Therefore, the fluctuating solar radiation profiles presented in Fig. 4 emphasize the importance of considering weather variability when evaluating the performance and energy sufficiency of the solar-powered maize shelling system, which is designed to operate independently of grid electricity and fossil fuels while maintaining sustainable functionality.

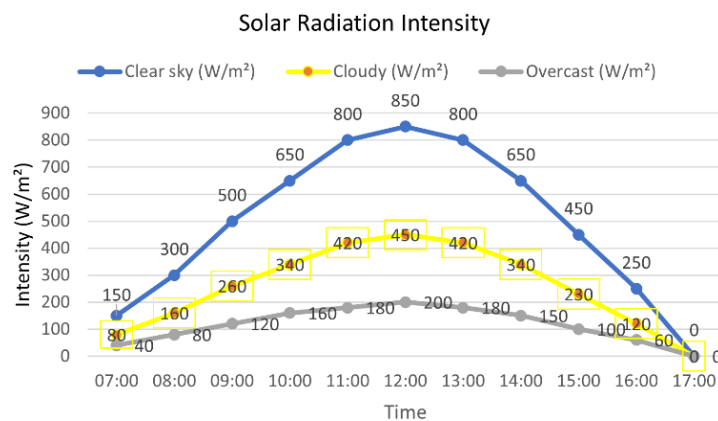

Fig. 4. Solar radiation intensity under clear, cloudy, and overcast conditions.

### 3.6 Economic analysis

Economic analysis is a crucial aspect in assessing the feasibility of using a solar-powered maize sheller compared to the PLN-based machine or fossil fuel-powered machines (gasoline/diesel).

The initial investment cost of the solar-powered maize sheller was calculated as the sum of the costs of all major system components, including the solar panel, battery, inverter, electric motor, charge controller, mechanical structure, and installation. Based on the component costs used in this study, the total initial investment cost of the system is estimated to be approximately IDR 12.15 million, indicating that the system is economically feasible for small-scale farmers and rural agro-processing applications. However, there is a key trade-off between the relatively higher initial investment cost of the solar power system compared with conventional systems and its significantly lower operating costs, as no fuel or grid electricity is required. Considering the annual operating cost savings, the system is expected to have a relatively short payback period, suggesting that its implementation can provide economic benefits in the medium to long term.

Table 6 shows a comparison of operational costs for various maize shelling machines. The operational cost per hour is calculated using the Levelized Cost of Energy (LCOE) approach, which is the ratio of the total system cost to the electrical energy produced over its lifetime [74], [75]. Based on the calculations, the motor's energy requirement is 0.125 kWh/hour. Assuming a solar LCOE of IDR 2,781/kWh, the operational cost is approximately IDR 348/hour, or equivalent to IDR 5.3 per kilogram of shelled maize at the prototype's capacity of 65 kg/hour.

Table 6. Comparison of operational costs

Type of machine	Operational cost (IDR/hour)	Cost per kg (IDR/kg)	Reference
Fossil-fuel engine (gasoline/diesel)	7,500	115	[67], [68], [69]
Grid-powered machine (PLN)	475	7.3	[67], [68], [70], [71], [72]
Solar machine (prototype)	348	5.3	[36], [67], [69], [73]

Gasoline-powered machines require about 0.5 liters per hour, with an average price of IDR 15,000 per liter, resulting in an operational cost of IDR 7,500 per hour, or approximately IDR 115 per kilogram of maize. Meanwhile, PLN-based machines require the same amount of electricity as the prototype (0.125 kWh/hour), with the unsubsidized electricity rate at IDR 3,800 per kWh, making the operational cost approximately IDR 475 per hour, or IDR 7.3 per kilogram. These results show that solar energy has the lowest operational cost, despite requiring a higher initial investment compared to a grid-powered machine.

The analysis shows that the solar-powered maize sheller performs competitively compared to grid-powered-based machine (PLN) and fossil fuel-powered machines, particularly regarding shelling efficiency, kernel damage rate, and operational costs. Although the prototype's shelling capacity of 65 kg/hour is still lower than the grid-powered-based machine (PLN) 90 kg/hour and fossil fuel machines' 150 kg/hour, the shelling efficiency of 90% is close to the PLN-based machine performance of 91.4% and modern portable machines at 90%. The relatively low kernel damage rate of 5% further confirms that the mechanical design and AC motor settings are effective, considering the impact of rotational speed and moisture content on output quality. In terms of energy efficiency, the 62.5% efficiency is still below the PLN-based machine 80%. Still, the operational cost advantage of IDR 348/hour or IDR 5.3/kg is far more economical compared to the PLN-based machine at IDR 7.3/kg or fossil fuels at IDR 115/kg. The results of this study show that while the solar-powered maize sheller has technical limitations in capacity and energy efficiency, it excels in sustainability, energy independence, and the potential for carbon emission reduction. The solar-powered maize sheller is an innovative solution highly relevant for smallholder farmers in rural areas and contributes to the renewable energy transition agenda and sustainable agricultural development.

Future studies may focus on optimizing battery management strategies, and refining the design of the shelling mechanism to increase machine capacity and durability. These developments are expected to enhance technical performance and broaden the practical application of the solar-powered maize sheller.

#### 4 Conclusions

The results of this study demonstrate that the solar-powered maize sheller is technically, economically, and environmentally feasible as an alternative post-harvest technology for smallholder farmers. The machine achieved shelling capacity of 65 kg/hour, while lower than that of fossil-fuel and the grid-powered maize shelling machine (PLN), was still much higher than manual methods. The shelling efficiency reached 90%, close to the PLN-based machine, with a low kernel damage rate of 5%, ensuring that the product quality was maintained. The energy efficiency of 62.5% indicates that there were still losses in the panel, battery, and inverter; however, its advantage lies in the lowest operational cost, only IDR 348/hour or IDR 5.3 per kilogram, which is far more economical than both grid-powered-based machines (PLN) and fossil fuel machines. Solar energy helps reduce production costs while decreasing dependence on grid-powered machines (PLN) and fossil fuels. This machine is relevant for increasing smallholder farmers' productivity and supports the renewable energy transition agenda. However, the implementation of solar-powered machines

in rural areas still faces several challenges, such as dependence on the availability of solar radiation, limited supporting infrastructure, and the need to increase user capacity in terms of equipment operation and maintenance.

#### Acknowledgements

Acknowledgment is extended to Sriwijaya State Polytechnic for their support in implementing this research.

#### References

- [1] A. S. Aljufri, Revi Syarlihan, Aris Abizar, "Preliminary design of shrimp pond paddle wheel powered by solar energy," *J. Polimesin*, vol. 19, no. 1, pp. 1–6, 2021.
- [2] D. Risky, M. Yusuf, and A. Setiawan, "Preliminary study on the use of solar energy to drive biomass briquetting machines," *J. Polimesin*, vol. 18, no. 2, pp. 114–150, 2020.
- [3] S. Gorjian, H. Ebadi, M. Trommsdorff, H. Sharon, M. Demant, and S. Schindele, "The advent of modern solar-powered electric agricultural machinery: A solution for sustainable farm operations," *J. Clean. Prod.*, vol. 292, p. 126030, 2021, doi: 10.1016/j.jclepro.2021.126030.
- [4] H. M. El Sharawy, A. H. Bahnasawy, Z. A. E. L. Haddad, and M. T. Afifi, "A local corn sheller performance as affected by moisture content and machine rotational speed," *Farm Mach. POWER*, vol. 34, no. November, pp. 2015–2034, 2017.
- [5] D. N. Karamov, P. V. Ilyushin, and K. V. Suslov, "Electrification of Rural Remote Areas Using Renewable Energy Sources: Literature Review," *Energies*, vol. 15, no. 4, 2022.
- [6] Y. Fahmi, "Renewable energy development towards indonesia 's energy transition: Technological innovations for a sustainable future," *J. Infrastruct. Sustain. Mobil.*, vol. 2, no. 2, pp. 95–109, 2025.
- [7] W. Bunganaen, Y. Toai, and D. Mangesa, "Rancang Bangun Mesin Pemipil Jagung Dengan Metode VDI 2222," *Lontar J. Tek. Mesin Undana*, 2022, doi: 10.35508/ljtmu.v9i02.9322.
- [8] L. Lewi, A. K. Muhammad, L. N. Ismayani, and A. Setiawan, "Rancang Bangun Sistem Pemipil Jagung Pada Sepeda Motor Listrik Roda Tiga," *J. Tek. Mesin Sinergi*, 2021, doi: 10.31963/sinergi.v19i2.3390.
- [9] A. Sai'in, E. Saputra, W. Nugroho, and R. T. Hardian, "Rancang Bangun Mesin Pemipil Jagung Dua Silinder menggunakan Motor Listrik," *J. Rekayasa Mesin*, 2021, doi: 10.32497/jrm.v16i3.3027.
- [10] Y. Nurmeji, Fendi Lisman and A. , Reza Syahriza, Mohammad Riza Nurtam, Musdar Effy Djinis, Irzal, "Rancang Bangun Alat Pemipil Jagung Sederhana," *Agroteknika*, vol. 2, no. 1, pp. 11–19, 2019.
- [11] S. Wakey, E. L. Tokoro, and W. W. Dharsono, "Desain Alat Proses Pelepas Biji Jagung Secara Sederhana Di Kabupaten Nabire," *J. FATEKSA J. Teknol. dan Rekayasa*, vol. 7, no. 1, pp. 54–64, 2022.
- [12] S. Uslianti, T. Wahyudi, M. Saleh, and S. Priyono, "Rancang Bangun Mesin Pemipil Jagung Untuk Meningkatkan Hasil Pemipilan Jagung Kelompok Tani Desa Kuala Dua," *J. Elkha*, vol. 6, no. 1, pp. 2–6, 2014.
- [13] Yahumri, Miswanti, H. Iswadi, T. Rahman, S. Yuliasari, and W. Mikasari, "Performance test and economic analyses of Semi Mechanic Corn Sheller," *IOP Conf. Ser. Earth Environ. Sci.*, vol. 715, 2021, doi: 10.1088/1755-1315/715/1/012074.
- [14] H. Haikal, B. Margono, M. Chamim, Z. R. Febriawan, and A. Wiyono, "Dissemination of corn sheller machines to increase productivity and efficiency for corn farmer associations in Wonogiri Regency," *Community Empower.*, 2021, doi: 10.31603/ce.5394.
- [15] B. F. Ibrahim, M. W. Wardana, and E. Khikmawati, "Pembuatan Alat Pemipil Jagung Kering Portable Untuk Kelompok Tani Side Karye Dusun Yagalaka Desa Sumur

- Kecamatan Ketapang Kabupaten Lampung Selatan,” *J. Bakti Masy. Manaj.*, vol. 2, no. 2, pp. 116–127, 2022.
- [16] A. Hasansyah Putra, R. Darmawan, R. Wijaya Keteknikan Pertanian, J. Teknologi Pertanian, and P. Negeri Jember, “Pembuatan dan Uji Kinerja Mesin Pemipil Jagung Ban,” *Jofe J. Food Eng. | E-ISSN*, vol. 1, no. 2, pp. 49–57, 2022.
- [17] A. Suprayitno, I. Dwi Purnomo, and H. Abd Rasyid, “The Effectiveness of Corn Sheller Machines for Increasing Farmers’ Income in Pasembon Village, Kotaanyar District, Probolinggo Regency,” 2021.
- [18] Y. Majeed *et al.*, “Renewable energy as an alternative source for energy management in agriculture,” *Energy Reports*, 2023, doi: 10.1016/j.egy.2023.06.032.
- [19] M. M. Rahman, I. Khan, D. Field, K. Techato, and K. Alameh, “Powering agriculture: Present status, future potential, and challenges of renewable energy applications,” *Renew. Energy*, 2022, doi: 10.1016/j.renene.2022.02.065.
- [20] A. Chel and G. Kaushik, “Renewable energy for sustainable agriculture,” *Agron. Sustain. Dev.*, vol. 31, pp. 91–118, 2011, doi: 10.1051/agro/2010029.
- [21] C. M. S. Kumar *et al.*, “Solar energy: A promising renewable source for meeting energy demand in Indian agriculture applications,” *Sustain. Energy Technol. Assessments*, 2023, doi: 10.1016/j.seta.2022.102905.
- [22] P. Karanjikar *et al.*, “Integration of Renewable Energy Solutions in Agricultural Operations,” *J. Geogr. Environ. Earth Sci. Int.*, 2024, doi: 10.9734/jgeesi/2024/v28i11835.
- [23] S. Asa’a *et al.*, “A multidisciplinary view on agrivoltaics: Future of energy and agriculture,” *Renew. Sustain. Energy Rev.*, 2024, doi: 10.1016/j.rser.2024.114515.
- [24] A. Schweiger and L. Pataczek, “How to reconcile renewable energy and agricultural production in a drying world,” *Plants, People, Planet*, 2023, doi: 10.1002/ppp3.10371.
- [25] H. Kim, I. Kim, J.-W. Seo, and J. Ko, “Smart Farm for Hydroponic Cultivation Using Integrated Renewable Energy Systems,” *IEEE Sens. J.*, vol. 24, pp. 35386–35393, 2024, doi: 10.1109/JSEN.2024.3449344.
- [26] A. Mohammed, “Integrated Hybrid Renewable Energy System Optimization for Sustainable Agricultural Operations,” *Process Integr. Optim. Sustain.*, 2024, doi: 10.1007/s41660-024-00464-w.
- [27] F. A. Ekoanindiyo, A. Yohanes, and E. Prihastono, “Perancangan Dan Pengembangan Alat Pemipil Jagung Menggunakan Tenaga Surya,” *J. Eng. Tek. Ind. Univ. Pancasakti*, pp. 13–21, 2019.
- [28] D. C. Dimas and Sulistiyanto, “Rancang Bangun Perontok Jagung Menggunakan Solar Cell,” *Informatics, Electr. Electron. Eng.*, vol. 2, no. 2, pp. 52–60, 2022, doi: 10.33474/infotron.v2i2.18630.
- [29] S. Gorjian *et al.*, “A review on opportunities for implementation of solar energy technologies in agricultural greenhouses,” *J. Clean. Prod.*, p. 124807, 2020, doi: 10.1016/j.jclepro.2020.124807.
- [30] A. Thakur *et al.*, “Advancements in solar technologies for sustainable development of agricultural sector in India: a comprehensive review on challenges and opportunities,” *Environ. Sci. Pollut. Res.*, vol. 29, pp. 43607–43634, 2022, doi: 10.1007/s11356-022-20133-0.
- [31] Y. Acosta-Silva *et al.*, “Applications of solar and wind renewable energy in agriculture: A review,” *Sci. Prog.*, vol. 102, pp. 127–140, 2019, doi: 10.1177/0036850419832696.
- [32] K. Manoj, “Solar Energy Applications for Agriculture: A Review,” *i-manager’s J. Power Syst. Eng.*, 2022, doi: 10.26634/jps.10.3.19031.
- [33] B. Ghritalahre and M. Quasim, “Development of Solar operated Maize Sheller,” *Int. J. Curr. Microbiol. Appl. Sci.*, vol. 9, pp. 738–743, 2020, doi: 10.20546/ijcmas.2020.906.094.
- [34] B. Ezurike, J. Osazuwa, and C. Okoronkwo, “Performance evaluation of an electric corn shelling machine for small scale indigenous industries in Nigeria,” *African J. Sci. Technol. Innov. Dev.*, vol. 12, pp. 355–364, 2020, doi: 10.1080/20421338.2019.1651480.
- [35] S. Ravindran, “Development of Mini Corn Shelling Machine,” *Interantional J. Sci. Res. Eng. Manag.*, 2025, doi: 10.55041/ijrsrem41774.
- [36] D. Annisa, “Analisis Kinerja Sistem Pembangkit Listrik Tenaga Surya On-Grid 10 kWp Pada Mesin Packer Pabrik Tonasa V,” 2023.
- [37] R. J. Barpatra Gohain, P. P. Dutta, and N. Bora, “Exergy, economic and environmental impacts analysis of a solar-biomass powered hybrid dryer for drying *Eryngium Foetidum*,” *Therm. Sci. Eng. Prog.*, vol. 59, no. October 2024, p. 103325, 2025, doi: 10.1016/j.tsep.2025.103325.
- [38] A. Mohan, J. U. Prakash, A. E. Kabeel, and A. M. Manokar, “Performance analysis of conventional solar still and solar still with crab shells as energy storage material,” *J. Energy Storage*, vol. 126, no. December 2024, p. 117071, 2025, doi: 10.1016/j.est.2025.117071.
- [39] Z. Aslam, S. I. U.-H. Gilani, T. I. Mohamad, M. Muhammad, and K. T. Alao, “Optical performance analysis of small-scale heliostats field layout of solar power tower system in Malaysia,” *Energy Nexus*, vol. 19, p. 100489, 2025.
- [40] E. Sulistiawati and B. E. Yuwono, “Analisis Tingkat Efisiensi Energi Dalam Penerapan Solar Panel Pada Atap Rumah Tinggal,” *Pros. Semin. Intelekt. Muda*, vol. 1, no. 2, pp. 325–330, 2019, doi: 10.25105/psia.v1i2.6658.
- [41]; Perianto Sitompul Salomo Silaban, “Instalasi Pembangkit Listrik Tenaga Surya Kapasitas 450 Watt,” *Sinergi Polmed J. Ilm. Tek. Mesin*, vol. 4, no. 1, pp. 41–48, 2023.
- [42] I. 9001 ISO, “Quality management systems – Requirements, Clause 8.3: Design and Development of Products and Services,” *Int. Organ. Stand.*, 2015.
- [43] T. S. Ramadhoni, A. Imam, Z. Anwar, B. Hidayati, and H. Sumarna, “Static Analysis of Electric Vehicle Prototype Frame,” *Int. J. Mech. Energy Eng. Appl. Sci.*, vol. 2, no. 1, pp. 26–35, 2024.
- [44] A. Jannifar *et al.*, “Model Mesin Perontok Padi Konvensional,” *J. Polimesin*, vol. 14, no. 1, pp. 1–6, 2016.
- [45] A. W. Aditya, N. R. Alham, R. Mukti, P. Negeri, and U. Mulawarman, “Web-based low-cost rooftop solar power plant for household applicatio,” *J. Polimesin*, vol. 21, no. 2, pp. 165–169, 2023.
- [46] H. D. Nahate, V. G. Kothalkar, and V. J. Hage, “Development and Performance Evaluation of Hand Operated Maize Sheller,” *INDIAN J. PURE Appl. Biosci.*, vol. 9, no. 1, pp. 113–117, 2021.
- [47] S. O. Nkakini, M. J. Ayotamuno, and S. D. Probert, “Manually-powered continuous-flow maize-sheller S.O.,” *Appl. Energy*, vol. 84, pp. 1175–1186, 2007, doi: 10.1016/j.apenergy.2007.05.009.
- [48] T. M. Azeez, I. D. Uchegbu, S. A. Babalola, and O. O. Odediran, “Performance Evaluation of a Developed Maize Sheller,” *J. Adv. Eng. Technol.*, vol. 5, no. 2, pp. 1–4, 2017.
- [49] R. Njue and N. Wawire, “On Farm Demonstration, Testing and Evaluation of Maize Sheller in Meru County,” *J. Agric. Sci. Technol.*, vol. 11, pp. 126–134, 2021, doi: 10.17265/2161-6264/2021.03.004.
- [50] B. S. N. Indonesia, “SNI 01-3920-1995: Jagung,” *Jakarta Badan Standar Nas.*, 1995.
- [51] S. E. A. P. Angin *et al.*, “Experimental test of the effect of PCM volume as thermal energy storage solar power in solar cooking units,” *J. Polimesin*, vol. 21, no. 5, pp. 538–542, 2023.
- [52] T. Zulfadli and A. Mulkan, “Studi kelayakan energi matahari – angin ( hybrid ) sebagai sumber daya pompa air untuk

- sistem pengairan di kawasan Aceh Besar ( Visibility study of hybrid solar-wind energy to power up the pump for the irrigation system in the District of Aceh Besar ),” *J. Polimesin*, vol. 17, no. 2, pp. 61–66, 2019.
- [53] A. S. Nugroho, “Uji Kapasitas Mesin Pemipil Tipe (Mct 5-60) Menggunakan Pully 3 Inchi,” no. 71, 2021, [Online]. Available: [http://eprints.poltektegal.ac.id/860/%0Ahttp://eprints.poltektegal.ac.id/860/2/acc\\_laporan\\_tugas\\_akhir.pdf](http://eprints.poltektegal.ac.id/860/%0Ahttp://eprints.poltektegal.ac.id/860/2/acc_laporan_tugas_akhir.pdf)
- [54] R. E. Putri, W. Nepis, and K. Fahmy, “Analisis Konsumsi Energi pada Beberapa Metode Pemipilan Jagung (*Zea mays* L.): Studi Kasus di Padang Pariaman Sumatera Barat,” *J. Teknotan*, vol. 15, no. 1, p. 53, 2021, doi: 10.24198/jt.vol15n1.9.
- [55] A. U. Seprilianzah and B. A. Hasyim, “Analisa Mesin Pemipil Jagung Semi-Otomatis Dilengkapi Blower,” *Jrm*, vol. 05, no. 01, p. 31, 2018.
- [56] A. H. Putra, R. Darmawan, S. Supriyono, and R. Wijaya, “Pembuatan dan Uji Kinerja Mesin Pemipil Jagung Ban,” *JOFE J. Food Eng.*, 2022, doi: 10.25047/jofe.v1i2.3140.
- [57] S. Ramadhan, M. Sapsal, J. Muhidong, and A. Info, “Performance Evaluation of a No-Husk Corn Sheller: A Case Study at Benteng Tellue Workshop,” *Salaga J.*, 2024, doi: 10.70124/salaga.v2i1.1743.
- [58] T. Pagasis, D. Mangallo, R. Allo, E. Tambing, S. Rantepulung, and M. R. Kaiway, “Application Of Mechanical Corn Shelling Machine To The Corn Farming Community Of Bibiosi Village Arso Swakarsa District Keerom District,” *Abdi Dosen J. Pengabd. Pada Masy.*, 2025, doi: 10.32832/abdidos.v9i1.2605.
- [59] S. Susilawati, M. Bin Ardin, S. S. S. Wibawa, and R. Septiana, “Proses Manufaktur Mesin Pemipil Jagung,” *J. Ilm. Ilmu dan Teknol. Rekayasa*, vol. 3, 2020, doi: 10.31962/JIITR.V3I1.80.
- [60] E. Gomaa, M. Omar, and S. Elsis, “Evaluation the Performance of the Locally Fabricated Maize Sheller Machine,” *J. Soil Sci. Agric. Eng.*, 2022, doi: 10.21608/jssae.2022.132958.1073.
- [61] R. Chandel and S. S. Thakur, “Optimizing Field Performance of Axial Flow Rotary Combine With Single Rotor and Snap Roll Header for Maize Harvesting,” *J. Agric. Sci.*, vol. 14, no. 3, p. 211, 2022, doi: 10.5539/jas.v14n3p211.
- [62] H. Asy’ari, N. Danang, and J. Putro, “Desain Pemipil Jagung dengan Sumber Energi Tenaga Surya dan Energi Listrik PLN,” *Emit. J. Tek. Elektro*, vol. 15, no. 2, pp. 47–52, 2015, [Online]. Available: <https://journals.ums.ac.id/index.php/emitor/article/view/2059>
- [63] A. Sai’in, E. Saputra, W. I. Nugroho, and R. T. Hardian, “Rancang Bangun Mesin Pemipil Jagung Dua Silinder menggunakan Motor Listrik,” *J. Rekayasa Mesin*, vol. 16, no. 3, p. 391, 2021, doi: 10.32497/jrm.v16i3.3027.
- [64] T. A. Susanto and Dermawan, “Rancang bangun mesin pemipil jagung skala industri rumah tangga,” *Pros. Semin. Has. Penelit.*, vol. 2017, pp. 18–24, 2017.
- [65] P. C. Chu, “Design and Performance Evaluation of Small Scale Corn Shelling Machine,” *Indones. J. Comput. Sci.*, 2024, doi: 10.33022/ijcs.v13i5.4480.
- [66] Q. Tang, L. Jiang, W. Yu, J. Wu, and G. Wang, “Design And Experiment Of High Moisture Corn Threshing Device With Low Damage,” *Inmateh Agric. Eng.*, 2024, doi: 10.35633/inmateh-74-15.
- [67] M. Lawal, “Construction and Performance Evaluation of a Solar Powered Maize Sheller for Rural Farmers,” vol. 2, 2020, doi: 10.36108/UJEES/0202.20.0170.
- [68] E. Mulenga, A. Kabanshi, H. Mupeta, M. Ndiaye, E. Nyirenda, and K. Mulenga, “Techno-economic analysis of off-grid PV-Diesel power generation system for rural electrification: A case study of Chilubi district in Zambia,” *Renew. Energy*, 2023, doi: 10.1016/j.renene.2022.12.112.
- [69] B. Robertson, J. Bekker, and B. Buckham, “Renewable integration for remote communities: Comparative allowable cost analyses for hydro, solar and wave energy,” *Appl. Energy*, vol. 264, p. 114677, 2020, doi: 10.1016/j.apenergy.2020.114677.
- [70] A. García, J. Gallagher, M. Chacón, and A. Nabola, “The environmental and economic benefits of a hybrid hydropower energy recovery and solar energy system (PAT-PV), under varying energy demands in the agricultural sector,” *J. Clean. Prod.*, vol. 303, p. 127078, 2021, doi: 10.1016/J.jclepro.2021.127078.
- [71] E. I. C. Zebra, H. Van Der Windt, G. Nhumaio, and A. Faaij, “A review of hybrid renewable energy systems in mini-grids for off-grid electrification in developing countries,” *Renew. Sustain. Energy Rev.*, 2021, doi: 10.1016/J.RSER.2021.111036.
- [72] C. Luerssen, O. Gandhi, T. Reindl, C. Sekhar, and D. Cheong, “Life cycle cost analysis (LCCA) of PV-powered cooling systems with thermal energy and battery storage for off-grid applications,” *Appl. Energy*, vol. 273, p. 115145, 2020, doi: 10.1016/j.apenergy.2020.115145.
- [73] E. Prihastono, A. Yohanes, and F. A. Ekoanindiyo, “Solar Corn Sheller Machine Design Based on Ergonomics Principles,” *J. Serambi Eng.*, 2023, doi: 10.32672/jse.v8i4.6684.
- [74] G. Manzolini *et al.*, “Limitations of using LCOE as economic indicator for solar power plants,” *Renew. Sustain. Energy Rev.*, 2025, doi: 10.1016/j.rser.2024.115087.
- [75] S. Abdelhady, “Performance and cost evaluation of solar dish power plant: sensitivity analysis of levelized cost of electricity (LCOE) and net present value (NPV),” *Renew. Energy*, vol. 168, pp. 332–342, 2021, doi: 10.1016/j.renene.2020.12.074.