

# STAND-ALONE SOLAR PV SYSTEM USING MPPT TECHNIQUE IN SIMSCAPE

Maimun<sup>1</sup>

<sup>1</sup>Electrical Engineering Department, Politeknik Negeri Lhokseumawe  
Email: maimun@pnl.ac.id<sup>1</sup>

**Abstract** – the stand-alone solar photovoltaic (PV) system mostly used by the islanded power electricity needed for rural area that located far away and unreachable from the national grid. Due to operate the system, the multiple power point tracker (MPPT) technique is used to support PV system to operate at its maximum power. The way the MPPT algorithm works is by calculating the output of PV module, then compares it to battery voltage then fixes what is the optimum power that PV module can produce to charge the battery and converts it to the optimum voltage to get maximum current into battery. It can also supply power to a DC load, which is connected directly to the battery. MPPT is very useful in cloudy days. This paper deploys the use of MPPT technique within the stand-alone solar PV system by simulating the designed Simscape model. Two MPPT techniques, which are the incremental conductance and perturbation and observation (P&O) have been chosen to be run as the system simulated. The parameters that have been observed are DC bus voltage, the PV power, the PV voltage, and the PV current, respectively. The results showed that the DC bus voltage raised and steady at the 377.3 V, the solar power increased to 2 kW, and the PV current decreased to approximately 7 A. The DC load is connected across the boost converter output. The solar PV system operates in both maximum power point tracking and de-rated voltage control modes. To track the maximum power point (MPP) of the solar PV, the two MPPT techniques incremental conductance and P&O might have been chosen.

**Keywords:** *Stand-alone solar PV, MPPT, Incremental Conductance, P&O, Simscape model.*

## I. INTRODUCTION

A solar photovoltaic (PV) system is made up of several photovoltaic solar cells. Depending on the capacity of the power plant or the amount of electricity generated, a group of modules can be connected in series or parallel to form an array. Despite the fact that the modules are created by the same manufacturers or from the same materials, but their performance characteristics differ, and the overall system performance changes depending on the efficiency or performance of the individual components. Solar PV system components include a battery charge controller, an inverter, an MPPT controller, and some low voltage (LV) switchgear[1]. According to reference [2], “Peak watt rating is a key performance measurement of PV module. The peak watt (Wp) rating is determined by measuring the maximum power of a PV module under laboratory Standard Test Conditions (STC)”.

PV systems that are designed and sized to serve DC and/or AC electrical loads are known as stand-alone PV systems. Many stand-alone PV systems use batteries for energy storage. In reference [3], it is stated that When sunlight shines on the PV module, DC power is generated. MPPT is connected to the PV module in order to maximize the DC output from the PV module due to the PV module's characteristic, which is dependent on temperature and irradiance. To prevent the system from shutting down at night, the generated DC power must be stored in the battery. The DC/DC converter converts the higher/lower DC voltage of the PV module into the lower/higher voltage needed to charge the battery. The

controller is in charge of regulating the energy flow from the solar panels to the batteries. Overcharging and discharging the battery are both prevented by the controller. The DC electricity from the batteries is converted to AC power by an inverter before being transferred to the AC load. The block design of a typical stand-alone PV system powering DC and AC loads with battery storage option is shown in Fig. 1.

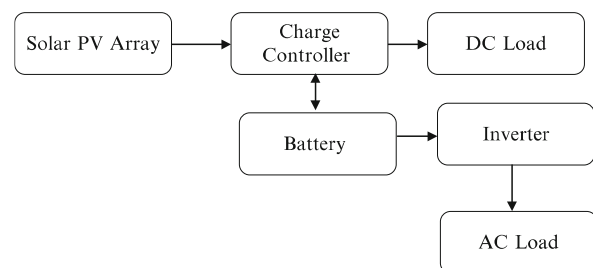

Fig. 1 Block Diagram of Stand-Alone PV System with Battery

MPPT's main purpose is to force the system to operate at maximum extracted power from PV panels under a variety of environmental conditions[4][5]. MPPT techniques differ in terms of the number of sensors, cost, complexity, effectiveness, and correct tracking for different irradiation and temperatures. Then you'll need a controller that pushes the PV system to operate at its maximum extracted power[5][6].

A normal PV module produces power with a maximum power voltage of around 17 V when measured at a cell temperature of 25°C; however, on a very hot day, it can dip to around 15 V, and on a very cold day, it

can soar to 18 V. The fundamental idea behind MPPT is to extract the most power out of PV modules by operating them at the most efficient voltage. MPPT calculates a PV module's output, compares it to the battery voltage, and then determines what is the best power that a PV module can supply to charge the battery and converts it to the best voltage to get the greatest current into the battery. It can also run a DC load connected directly to the battery. On cloudy days or when the battery is entirely exhausted, MPPT is very useful[2].

There are several techniques of MPPT to be implemented within the solar PV system[2], namely

1. Perturb and Observe (hill climbing method).
2. Incremental Conductance method.
3. Fractional short circuit current.
4. Fractional open circuit voltage.
5. Fuzzy logic.
6. Neural networks.
7. Ripple Correlation Control.
8. Current Sweep.
9. DC-link capacitor droop control.
10. Load current or load voltage maximization.
11.  $dP/dV$  or  $dP/dI$  Feedback control.

This paper deploys the MPPT technique for stand-alone solar PV system with battery storage that used the incremental conductance and perturbation and observation (P&O) methods whereas a boost converter is utilized to control the output power of the system.

The paper is organized into four sections, namely the introduction of the article that discussed the background of the problem, a brief literature review, the aims and objectives of the carried-out research. Added in section two the method that used to mitigate the research and then continued to section three the discussion of the results and ended with section four the conclusions.

## II. METHOD

Stand-alone loads are supported by both solar PV and battery storage. The load is connected across the DC output that is always constant. Maximum power point tracking and de-rated voltage regulation are two modes of operation for solar PV systems. Bi-directional DC-DC converters are used in the battery management system.

Six standard operating modes are required for a stand-alone PV system, based on solar irradiation, generated solar power, connected load, battery SOC, and maximum battery charging and discharging current restrictions. The author chose between two MPPT strategies to track the maximum power point (MPP) of solar PV: incremental conductance and perturbation and observation.

The MPPT algorithm can be utilized with both buck and boost power converters, depending on the system design. When the battery system voltage is equal to or less than 48 V, buck converters are commonly employed. A boost converter should be utilized if the battery system voltage is more than 48 V.

The P&O approach integrates a change in the duty cycle of the power converter as well as a change in the operating voltage of the DC-link between the PV array and the power converter in the algorithm. Changing the duty cycle of the power converter involves changing the voltage of the DC-link between the PV array and the power converter. The previous perturbation's sign and the prior power increment's sign determine the following perturbation. If the power grows, the perturbation should grow in the same direction; if the power drops, the next disturbance should grow in the opposite direction. The method is carried out until the MPP is attained[2].

Furthermore, the array terminal voltage is always adjusted according to the MPP voltage in the incremental conductance technique, which is based on the PV module's incremental and instantaneous conductance[7].

A boost converter transfers lower voltage to higher voltage using a DC-DC converter. An inductor, switching device, diode, capacitor, load, and gate signal for switching device make up a standard boost converter. In a solar PV system, a boost converter with MPPT algorithm is utilized to generate maximum power under various weather conditions while maintaining constant voltage across the load. The stored current from the inductor is converted to load through the diode by switching MOSFET on and off. Using a large capacitor, the output voltage is kept steady and continuous[8].

A boost converter controls the output power of a solar PV system and assists in determining how the panels should be placed in terms of the number of series-connected strings and panels per string in order to obtain the desired power rating. Use a boost converter to implement the MPPT algorithm. Then switch to voltage control mode on the solar PV system. Select a suitable proportional gain  $K_v$  and phase-lead time constant  $T_v$  for the PI controller,  $\frac{K_v(sT_v+1)}{sT_v}$ .

Fig. 2 illustrates the equivalent circuit of the boost converter with MPPT.

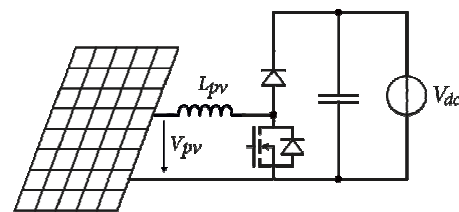

Fig. 2 Boost Converter with MPPT[8]

### A. Solar PV System with MPPT using Boost Converter Model

The model's description and settings are as follows. PV plant specifications for the specified solar panel have a power rating of 2.00 kW entered by the user. A minimum of eight panels are required for each string. The greatest number of panels that can be linked to a string without exceeding the maximum voltage is ten. The solar PV plant's minimum power rating is 1.80 kW. The maximum power per string that can be generated

without exceeding the maximum DC voltage is 2.25 kW. The number of panels per string is actually nine. The actual solar PV plant power is 2.03 kW, and a PV string is linked in parallel.

**B. Simscape Model**

To open a script that designs the standalone PV system, at the Matlab® by using the command line for DC power system.

```
edit'ee_solar_boostconverter_maxpowerpoint_data'.
```

The system can be seen in Fig. 3.

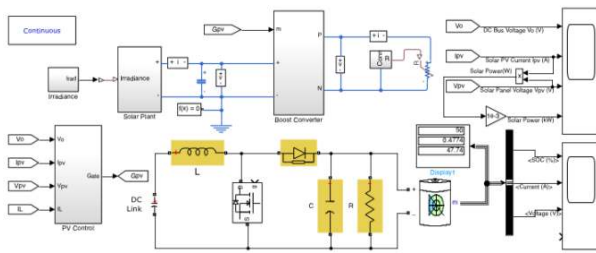

Fig. 3 Complete System that Run on Simscape

**III. RESULTS AND DISCUSSION**

The model is simulated under constant cell temperature of 25°C and different irradiation level and the output of the PV module model is fed into the boost converter.

The parameters that have been monitored from the simulation for the solar PV panel are the DC bus voltage ( $V_o$ ), the solar power ( $W$ ), the solar panel voltage ( $V_{pv}$ ), current ( $I_{pv}$ ) and power (kW), respectively. Furthermore, the parameters that have been monitored from the simulation for the battery are the percentage of the battery state of charge (SOC), the battery current and the voltage, respectively.

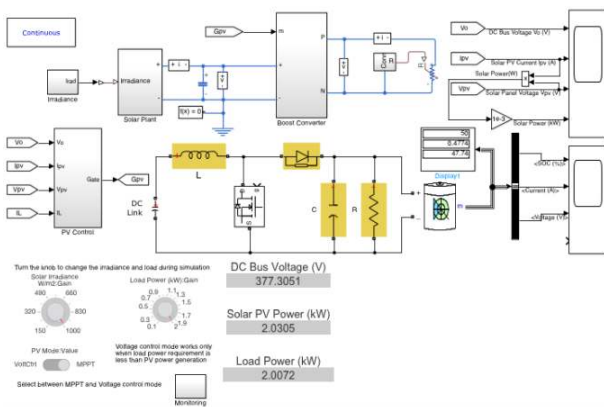

Fig. 4 Simscape of Stand-Alone Solar PV System with Battery and Monitor System[9]

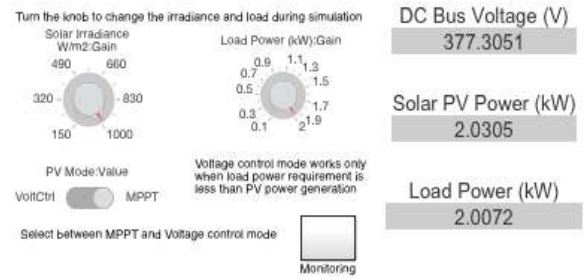

Fig. 5 Monitoring System

The results showed that the close match between the output of converter with constant DC input and the PV fed the converter. The output voltage and current of the PV then fed the boost converter and obtained for change of irradiation levels at constant temperature.

The solar plant subsystem simulates a solar plant with parallel-connected solar panel strings. The Solar Cell block from the Simscape™, Electrical™ library is used to model the solar panel. Using the specified DC bus voltage, solar cell characteristics, and power rating, the solar panel string length and number of parallel-connected threads are determined. Connecting several panels may slow down the simulation as the number of elements in a model grows. By assuming constant irradiance and temperature across all solar panels and using the controlled current and voltage sources as described in the solar panel subsystem, it is possible to reduce the number of solar elements. The variation subsystem is used to implement two MPPT approaches. To use the P&O MPPT approach, set the variation variable MPPT to 0. To use the incremental conductance approach, set the variable MPPT to 1.

The solar PV power is controlled by a boost DC-DC converter. Both MPPT and voltage control modes are supported by the boost converter. When the load power is less than the maximum power provided by a solar PV plant due to incident irradiance and panel temperature, the voltage control mode is utilized.

The battery management system employs a bi-directional DC-DC converter. The battery is charged by the buck converter, while it is discharged by the boost converter. To improve battery performance and life cycle, systems with battery backup have reduced the maximum battery charging and discharging current. The maximum charging power is equivalent to the solar plant capacity in the standard test setting. The battery should be able to be recharged faster than the user-specified recharge time with the highest charging power selected.

Fig. 6 shows the DC bus voltage, Solar PV current, voltage and power, respectively as the simulation run within 0.5 second continuously. As the results, the DC bus voltage ( $V_o$ ) raised and steady at the 377.3 V, the solar power ( $P_{pv}$ ) increased to 2 kW, and the PV current ( $I_{pv}$ ) decreased to approximately 7 A. However, the PV voltage ( $V_{pv}$ ) started to increase from 210 V to 270 V at halfway (0.25 second) of the simulation.

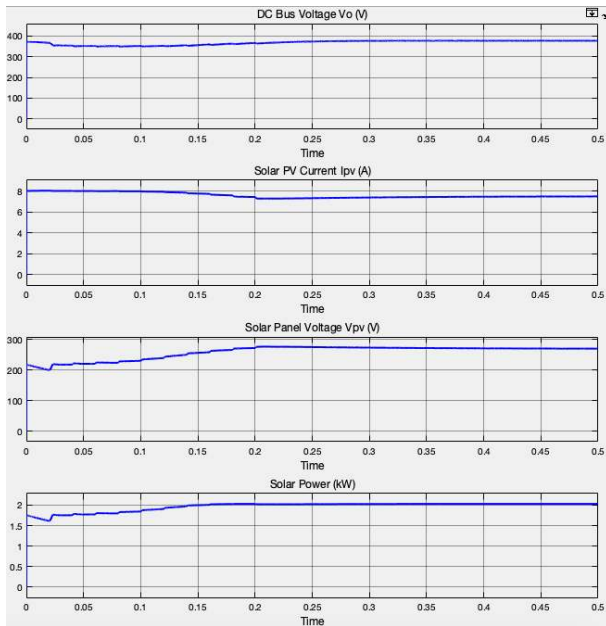

Fig. 6 Measured PV System Parameters

Meanwhile, Fig. 7 shows the percentage of battery SOC, and the battery current and voltage within the 0.5 second. The battery SOC reached 50% of its charge capacity with the current of 10000 A and the voltage of 48 V.

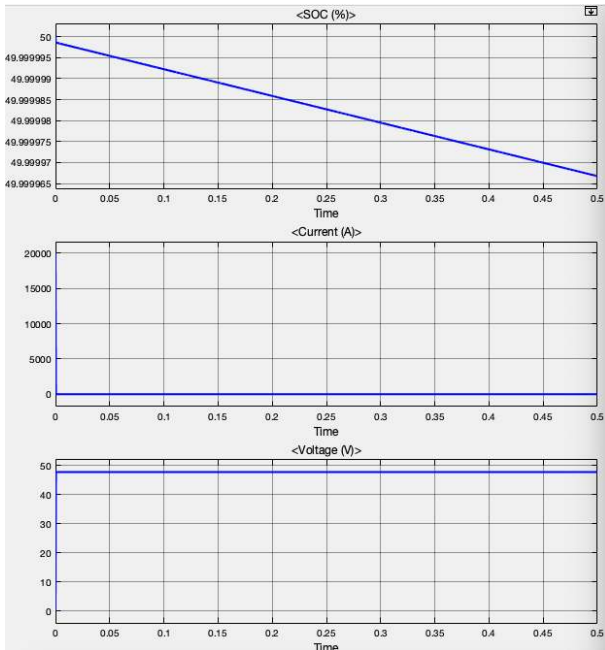

Fig. 7 Measured Battery Parameters

Fig. 8 illustrates the battery discharge characteristics. As the Lithium-ion battery is used with the nominal voltage of 48 V, rated capacity 200 Ah, and initial SOC 50%, at the nominal discharge current of 40 A, the discharge voltage is 48 V (reached its nominal value) with its measured current of 6.5 A.

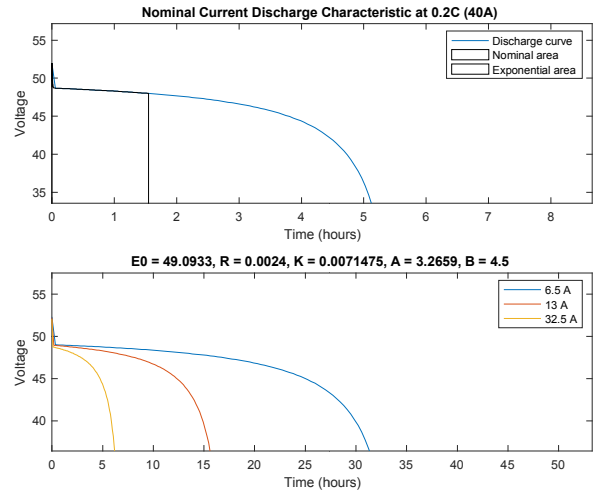

Fig. 8 Battery Discharge and Current over Time Characteristics

### III. CONCLUSION

In this paper, the effect of the boost converter and the MPPT with the P&O and incremental conduction methods have been utilized in the stand-alone solar PV system in order to get the maximum power and the output voltage has been boosted up by the boost converter. The output of the boost converter varied with the change of inductor, resistance and capacitor. The incremental conductance algorithm is able to automatically adjust according to characteristics of PV system.

The results showed that the DC bus voltage raised and steady at the 377.3 V, the solar power increased to 2 kW, and the PV current decreased to approximately 7 A. The DC load is connected across the boost converter output. The solar PV system operates in both maximum power point tracking and de-rated voltage control modes. To track the maximum power point (MPP) of the solar PV, the two MPPT techniques incremental conductance and P&O might have been chosen.

### REFERENCE

- [1] Sridhar, R., Jeevananathan, D., ThamizhSelvan, N., & Banerjee, S. (2010). Modeling of PV array and performance enhancement by MPPT algorithm. *International Journal of Computer Applications*, 7(5), 0975-8887.
- [2] Sai, Sumathi & Kumar, L Ashok & Paneerselvam, Surekha. (2015). Solar PV and Wind Energy Conversion Systems. 10.1007/978-3-319-14941-7.
- [3] Abdul Rahman, N. H., & Omar, A. M. (2014). Modeling of a maximum power point tracker for a stand-alone photovoltaic system using MATLAB/Simulink. *International Journal of Low-Carbon Technologies*, 9(3), 195-201.
- [4] Ismatkhodgaev, S. K., Matchanov, N. A., Azizov, S. A., & Suleymanov, S. I. (2014). Advanced technologies of development of power engineering and energy supply of the republic economy. *Applied Solar Energy*, 50(3), 191-195.

- [5] Ibbini, M. S., & Adawi, A. H. (2020). A SIMSCAPE based design of a dual maximum power point tracker of a stand-alone photovoltaic system. *International Journal of Electrical & Computer Engineering (2088-8708)*, 10(3), 2912-2917.
- [6] Shiau, J. K., Wei, Y. C., & Chen, B. C. (2015). A study on the fuzzy-logic-based solar power MPPT algorithms using different fuzzy input variables. *Algorithms*, 8(2), 100-127.
- [7] Yadav, Dilip & Singh, Nidhi. (2014). Simulation of PV System with MPPT and Boost Converter. IEEE Sponsored National Conference on Energy, Power and Intelligent Control Systems.
- [8] Karki, P., & Adhikary, B. (Oktober, 2013). MATLAB/Simulink based modeling and simulation of grid-connected solar photovoltaic system in distribution power network. In *Fifth International Conference on Power and Energy Systems, Kathmandu, Nepal* (pp. 28-30).
- [9] Mathworks®. Solar PV System with MPPT Using Boost Converter, Support-Documentation, diakses 2 Agustus 2021 <https://au.mathworks.com/help/physmod/sps/ug/solar-pv-system-maximum-power-point-tracking-using-boost-converter.html>.