

Modelling Home Appliances of DC House Based on Rooftop Photovoltaic Power Supply

Siti Amra

Electrical Engineering Department, Politeknik Negeri Lhokseumawe
Email: siti amra@pnl.ac.id

Abstract –The implementation of rooftop photovoltaic (PV) system in Indonesia mostly using inverter to convert the DC voltage supply into AC voltage supply to power the AC home appliances. This inverter is a complex and expensive electronics system. Many of the rooftop PVs are in fault condition due to the failure of their inverters. Therefore, the trends of applying everything's DC source has been recently developed. This paper examines the modelling of several home appliances (i.e., refrigerator, television, washing machine, air conditioner, crockpot, laptop, mobile phone charger, and LED lightings) of a DC house, which is powered by the rooftop PV using the MATLAB/SIMULINK platform. This proposed model considers the PV (solar cell) module, chargecontroller, battery, and the home appliances as the end load of the system. As the results, this model then analyses and compares to the PV system that powered the AC home appliances to get better vision of DC home appliances that can be implemented in the community.

Keywords: Home appliances, DC house, Rooftop PV, MATLAB/SIMULINK.

I. INTRODUCTION

The trend of using direct current (DC) to supply power to the load becomes popular since it has various advantages over the alternating current (AC) power supply. Additionally, the power supplied from photovoltaic (PV) array is in DC consequently makes the system looks less complex. Besides, numerous of today's customer loads are available at low voltage DC such as Led lightings and hand phone chargers[1]. The progression achieved in power electronics has made the DC voltage regulation less demanding and more efficient. Today's solid-state switching DC converters have power conversion efficiency within the range of 95%[2]. Compared to AC system, the energy conversion losses of DC system are minimized [3] since there is no reactive power[4]. For off-grid homes, a solar DC solution has been proposed by Kaur, 2015 where it utilized solar DC power to feed the loads and maintains a strategic distance from numerous AC/DC conversions.

The fundamental concept of low voltage direct current (LVDC) grid is similar with LV distribution of AC. According to reference [5] the flow of electricity through cables and components to the end-user at low voltage levels might defer in nature, characteristics or functions, therefore, the difference in between both alternatives rest on the way that the system is configured.

Therefore, the objective of this paper is to highlight the technical modelling of solar PV DC system to generate sufficient energy for household customer group that consumed certain kWh per month so that they are no longer depend on energy from the public grid. The energy distribution to the loads then completely in DC due to avoid the use of inverter. This model can reduce energy loss due to inverter, and

increase the energy efficiency. In addition, the results are then compared to the solar PV AC system with similar load setup.

This paper arrangement is as follow, first section discusses briefly regarding the need of using DC power to supply DC house and its DC home appliances. Second section highlights the model of the home appliances (for examples, refrigerator, television, washing machine, air conditioner, crockpot, laptop, mobile phone charger, and LED lightings) of a DC house based on rooftop PV power supply. The third section then provides the results of the proposed model in the MATLAB/SIMULINK platform. Finally, the last section concludes the merit of the proposed model.

II. METHODS

As it has been mentioned in author previous paper[6], the comparison of power loos reduction of DC house to AC and listed in Table 1.

Table I
Comparison of Power Loss Reduction

House Type	Cooling Load	Conversion Reduction	Storage Direct-DC Savings
AC House	AC/DC power supply	10% less to 7%	12.8% less to 9.3%
	Non-cooling load AC/DC power supply	13% less to 10%	
DC House	DC/DC converter (380/24V)	5% less to 3%	12.8% become 13.7%
	Rectifier (AC/DC)	7% less to 5%	

Following the advantages that we get from Table 1, hence the steps of modelling the DC home appliances begins with proposing the model, setting up the configuration and values for the rooftop PV's components (i.e., PV module, controller charger, battery, and the home appliances (i.e., refrigerator, television, washing machine, air conditioner, crockpot, laptop, mobile phone charger, and LED lightings) as the end load of the system. then continue to perform the simulation into MATLAB/SIMULINK platform.

A. Proposed Model

For the PV system from PV module to the battery, we used the one that mitigated in[6], while for the DC load, we modelled it based on[7]. Fig. 1 illustrates the schematic of the proposed model for the PV system part, where the charge control and maximum power point tracker (MPPT) interacts with PV module and battery, and also interacts with rectifier (DC/DC). Then to the end loads.

Power is distributed at maximum power load 380V DC and minimum power load 24V DC. In the direct-DC, power from PV power system (including battery) sent directly to DC home appliances. PV module needs MPPT, to provide the necessary constant voltage to the load and adjusts the apparent load characteristics that have been seen by PV module to force its maximum power output. In addition, a rectifier (DC-DC converter) is needed to convert high voltage DC that comes from the PV module to supply the low power loads.

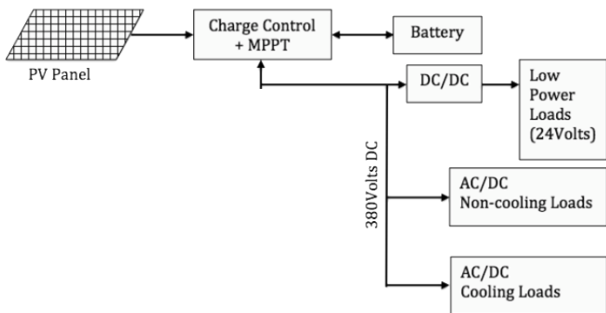

Fig. 1 Schematic of The Proposed Model of PV System to The End Loads

For the end loads, we need to consider the efficiency towards the PV system components. Table 2 listed the efficiency of the low power loads 24V DC (laptop, mobile phone charger, LED lightings) AC/DC non-cooling loads 380V (television, washing machine, and crockpot), and AC/DC cooling loads 380V (refrigerator and air conditioner).

Table II Load efficiency toward PV system's components

PV system Components	Full-load efficiency	Part-load Efficiency
PV Module	95%	90%
Charge Controller + MPPT	98%	94%
Battery	97%	92%
Rectifier (meter to DC)	93%	84%

Besides the load efficiency towards the PV system, we also need to consider the direct-DC loads as severely mentioned in[7]. The load is separated into cooling, non-cooling, and low power load, for conceptual clarity, because of the different nature of these loads with respect to the potential utilization of direct-DC. Exclusively, the timing of these loads with respect to PV system output suggests different utilities:

- Cooling loads have the greatest temporal overlap with PV system output and therefore offer the best potential for energy savings from direct-DC.
- Non-cooling loads will generally be synchronous with PV output for the commercial sector and not so for the residential sector.

B. Configuration Setup

The system configuration must identify the maximum charging capacity of battery 1kWh-5kWh. The battery efficiency is assumed to be 90% in one-way and 81% in round-trip. However, it could vary depends on storage and the battery state of charge. Table 3 summarizes the power characteristics and life time of the mentioned PV system's components.

Table III Power Characteristics and Lifetime of Direct-DC PV System's Components

Components	Power Characteristics	Lifetime
PV Module	Anti-islanding and Similar to uninterruptible power supply (UPS)	2 years standard warranty, extended 5 years warranty on this model
MPPT	Input voltage range 12V DC in small charge controller	20-25 years warranty
Charge Controller	Operating range 4.5-80A	16-25 years warranty
Battery	Lead-acid battery wired in series, applied at 12V, 24V and 48V temperature 75°F	15-20 years warranty, approximate 1600 Ah
Rectifier	For residential produces low power	10 years warranty

Additionally, to determine the home appliances energy consumption, firstly we must consider the function embodied in them and the developed technology towards them. Through Table 4, we can see the functions and developed technology of DC home appliances listed. However, we must consider that all of the replacement technologies indicated in the table are DC friendly, the savings are based on demonstrated or engineered design options that may include other energy saving components as well. Table 5 listed the DC home appliances the energy consumption that we used later in the proposed model.

As we notice the PV system's components power characteristics and energy consumptions, then we can

manage to set up each component's value then model and simulate the system in the MATLAB/SIMULINK platform.

Table IV
Functions Embodied in Appliances and DC Technologies that can Serve Those Functions[7]

Functions within Appliances	Appliance Components	Standard Technology	DC Technology
Lighting	Incandescent, fluorescent, and LED lamps	Incandescent	Electronic (fluorescent or LED)
Heating	Electric resistance heater	Electric resistance	Heat pump for space and water heating applications, resistance heating for small applications
Cooling	Motors driving compressors, pumps, and fans	Induction motor, single speed compressor, pump, and fan where applicable	Variable speed drive driven by brushless DC permanent magnetmotors
Mechanical works	Motors	Induction motors	brushless DC permanent magnetmotors
Computing	Electronics	Digital circuits	Idem

Table V
Energy Consumption of Home Appliances

Appliances (DC Compatible)	Type	DC Voltage (Volt)	Energy Consumption (Wh)
Refrigerator	Domestic refrigerator and freezer	48	127
Television	Colour TV and set-top box	12/24	108
Washing Machine	Clothes washer and dryer	48	188
Air Conditioner	Room split-cool	48	127
Crockpot	Cooking equipment	48	131
Laptop	Rechargeable electronics	12/24	19
Mobile Phone Charger	Rechargeable electronics	12/24	9
LED Lightings	LED lamps	12/24	17

C. MATLAB/SIMULINK

In reference [8], it indicates the advantages of using MATLAB/SIMULINK platform to create a DC house model. SIMULINK toolbox of the MATLAB software is an extremely powerful tool that can be used to model anything from complex thermodynamic reactions to

electric circuit simulation. It operates on the fundamental principles behind any known process.

In the case of electrical circuits, it relies on the mathematical equations that model each component such as resistor, transformer, inductor and capacitor to create a simple user interface that can model complex circuits. MATLAB/SIMULINK can also model logic operations using more abstract diagramming, which makes it easier to model controls for electrical devices. Normally these electrical controls are modelled abstractly and then translated into electronic circuits that carry out these logic functions. Simulink removes this tediousness, as well as provides versatility to model devices other than electric circuits. SIMULINK/MATLAB provides a different set of advantages for simulating small-scale DC systems. It can model both transient and steady state operations accurately, but requires extra effort to build the initial model. It also provides the ability to create models for devices that no exist in the libraries of other simulation software, or provide more detailed behaviours for those generic devices that already exist. The trade-off is that it does not have very many devices already modelled in its library set for power systems. Instead it provides many basic components that can be configured into more complex models.

This powerful combination makes it the perfect program to use for a simulation of the DC house's power distribution system[8].

III. RESULTS AND DISCUSSION

Basic overview of the proposed DC house model with its home appliances as the DC loads was adopted from [8], whereas the DC house is powered from a single ideal voltage source, in this case the PV module.

A. Simulation of the Proposed Model

Firstly, we create the PV system components without end loads. The value of each component that we set assumed is ideal. Each component is modelled separately before they combined into the complete system. Fig. 2 illustrates the PV with battery model.

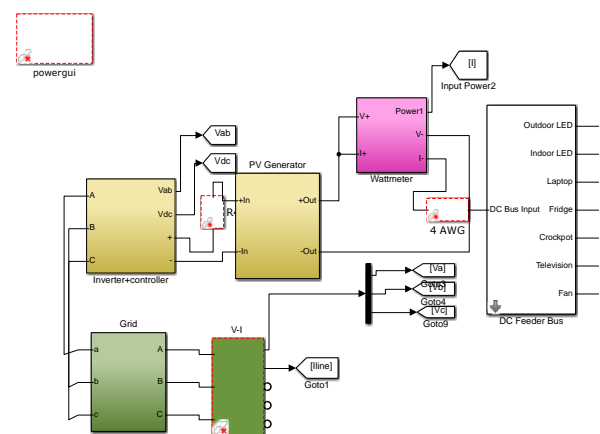

Fig. 2 PV with battery model

Then we create the model of the loads, namely the DC home appliances that illustrated in Fig. 3. Finally, we combine them into the complete model as can be seen in Fig. 4. The modelling simulates efficiencies that

represent the high-end current. Since the DC house power system is imaginary, then the characteristics assumed to be similar for each component.

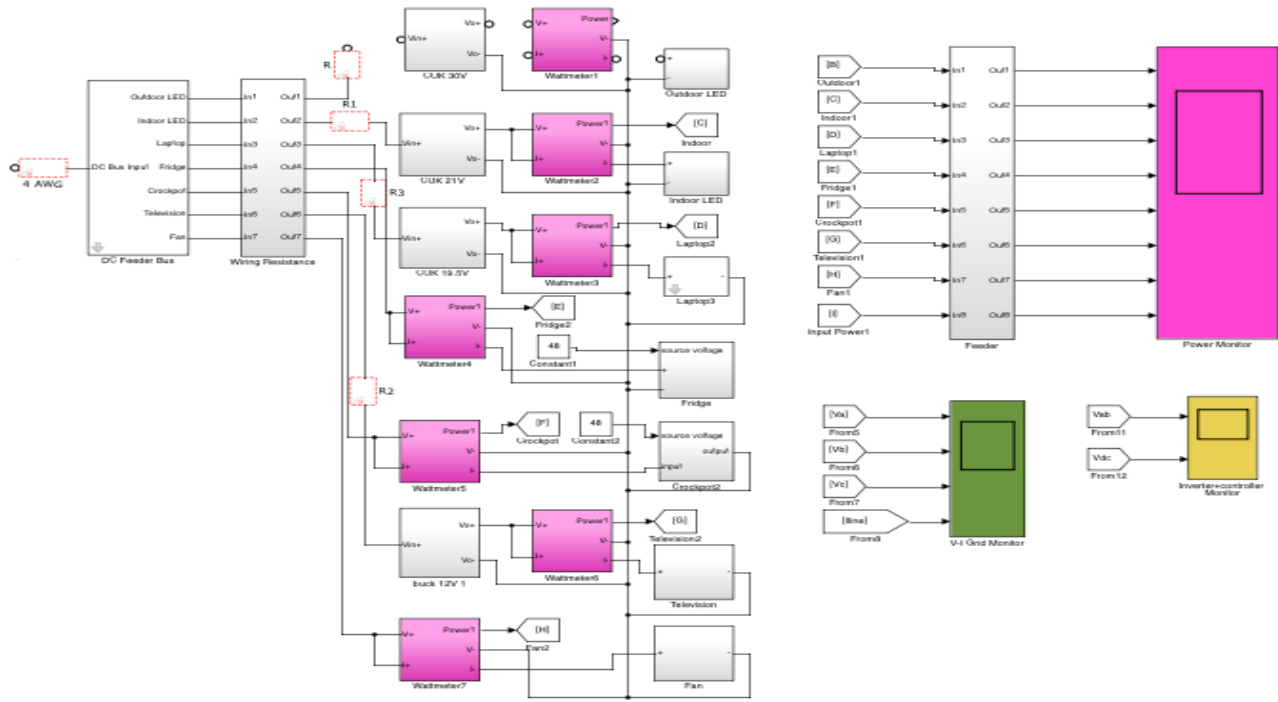

Fig. 3 Home Appliances Model

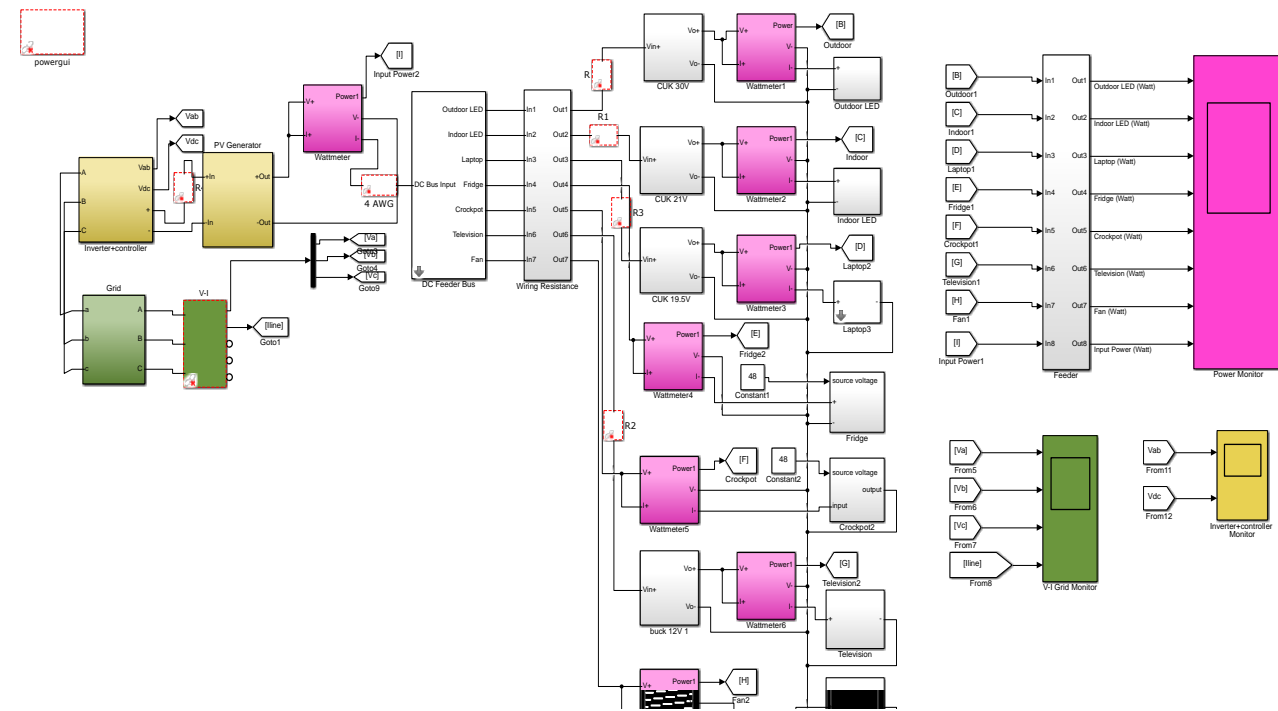

Fig. 4 Complete PV System Proposed Model

B. Simulation Results

The proposed simulation model of PV system for DC house was run properly in MATLAB/SIMULINK and performed a very well efficiency through several DC voltage level variation. The voltage bus level affected the efficiency in several ways. A low voltage bus for the same power levels meant high currents. High currents then create large power losses in the resistive wiring from the bus to the loads. These high currents also create significant voltage drops from the sending end of the bus to the receiving end of the bus where loads were attached.

Fig. 5 illustrates the efficiency of the proposed simulation model of PV system for DC house. As can be seen, the peak efficiency under the standard settings is approximately at 40V. The reason that the efficiency initially increases drastically, is because of the increased voltage is resulted in drastically less currents, and therefore power loss in the linesless occurred. The Efficiency gains are minimized at higher voltages, because the resistive losses due to current are the result of an exponential function of $P_{resistor} = I^2 \cdot R$. Therefore, as the current decreases, the power approaches zero exponentially, with drastic changes at the beginning, and more subtle changes at very small currents.

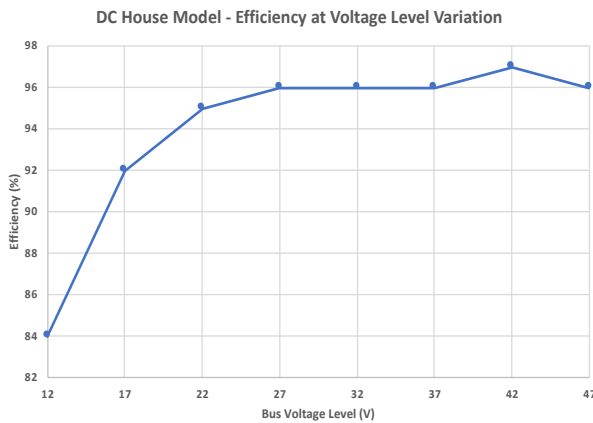

Fig. 5 DC House Model Efficiency at Varied Voltage Level

Additionally, the efficiency of home appliances (refrigerator, television, washing machine, air conditioner, crockpot, laptop, mobile phone charger, and LED lightings) were also being performed through several DC voltage level and shown the similar circumstances (Fig. 6).

The author then simulated a case of day and night cycles, whereas some loads were divided to be used at day time and night time. At the day cycle scenario, the lightings, television, laptop and mobile phone were disabled. However, the crockpot, air conditioning, washing machine and refrigerator were enabled. Even though, refrigerator is enabled all day long (day and night cycle). For night cycle, lightings, refrigerator, television, laptop, mobile phone, and air conditioning were enabled. Fig. 7 illustrates the efficiency of day and night cycles of the load and compare them to the standard efficiency.

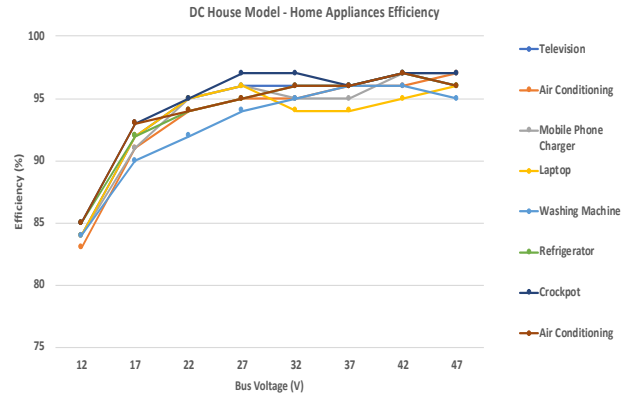

Fig. 6 Home Appliances Efficiency at Varied Voltage Level

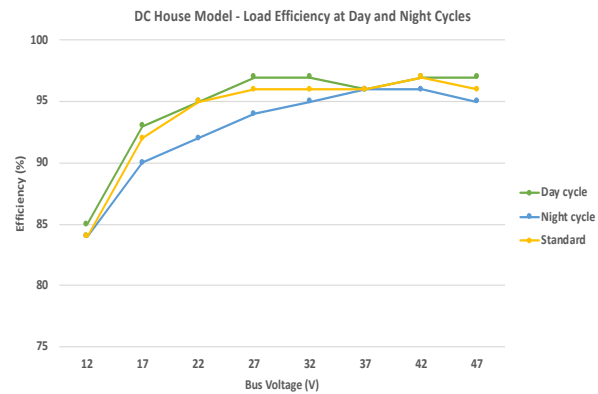

Fig. 7 Efficiency of Load through Day and Night Cycles

As for the results in Fig. 7, it can be seen that day cycle has no similar peak of efficiency at around 40 volts as all the other power profiles have had. This is probably because the loads which use rectifier are all disabled for the day cycle. Since we considered the rectifier become slightly less efficient at higher voltages, then the night cycle efficiency indicates the distinct notch in the graph at around 40V. Additionally, it is worth noting for both day and night cycles, which are more efficient than the standard load. This is because the system is operating at a reduced power, and the relative impact of current losses is reduced. Therefore, the system operates more efficiently at lower loads.

IV. CONCLUSION

This paper demonstrated a SIMULINK/MATLAB model of a DC house with DC home appliances that has been powered by rooftop PV system. This DC house model provides efficiencies of the system and the full-loads DC appliances through several DC voltage level (12-48V DC). It also provides a specific case that showing the day and night load cycles. This model could easily implement to the rural homes whereas no complex home appliances were used.

REFERENCE

- [1] Shah, K., Chen, P., Schwab, A., Shenai, K., Gouin-Davis, S., & Downey, L. (2012, May). Smart efficient solar DC micro-grid. In *2012 IEEE Energytech* (pp. 1-5). IEEE.
- [2] Taufik, T. (2014, October). The DC House project: An alternate solution for rural electrification. In *IEEE Global Humanitarian Technology Conference (GHTC 2014)* (pp. 174-179). IEEE.
- [3] Elsayed, A. T., Mohamed, A. A., & Mohammed, O. A. (2015). DC microgrids and distribution systems: An overview. *Electric power systems research*, 119, 407-417.
- [4] Shenai, K., & Shah, K. (2011, May). Smart DC micro-grid for efficient utilization of distributed renewable energy. In *IEEE 2011 EnergyTech* (pp. 1-6). IEEE.
- [5] Anand, S., & Fernandes, B. G. (2010, November). Optimal voltage level for DC microgrids. In *IECON 2010-36th Annual Conference on IEEE Industrial Electronics Society* (pp. 3034-3039). IEEE.
- [6] Amra, S., Safitri, N., Akhyar, A., & Usardi, U. (2017). Direct-DC Power System Generation Based on Single-Phase Rooftop Photovoltaic in Residential Low Voltage Feeder. *Journal of Multidisciplinary Academic*, 1(1), 15-20.
- [7] Garbesi, K., Vossos, V., and Shen H.. (2012). Catalog of DC appliances and power systems. Energy Analysis Department - Environmental Energy Technologies Division Lawrence Berkeley National Laboratory Berkeley, CA.
- [8] Crowfoot, J. J. (2011). Design and Modeling of the Cal Poly DC House Power Distribution System. A thesis in Master of Science in Electrical Engineering, the Faculty of California Polytechnic State University, San Luis Obispo.